

MANUAL TRANSMISSION (Non-Turbo)

INDEX	J1- 2
OUTLINE	J1- 3
SPECIFICATIONS.....	J1- 3
STRUCTURAL VIEW.....	J1- 4
POWERFLOW	J1- 5
TROUBLESHOOTING GUIDE	J1- 6
TRANSMISSION OIL	J1- 7
INSPECTION	J1- 7
REPLACEMENT.....	J1- 7
TRANSMISSION	J1- 8
PREPARATION	J1- 8
REMOVAL	J1- 9
DISASSEMBLY	J1-11
INSPECTION	J1-21
ASSEMBLY	J1-24
INSTALLATION.....	J1-43

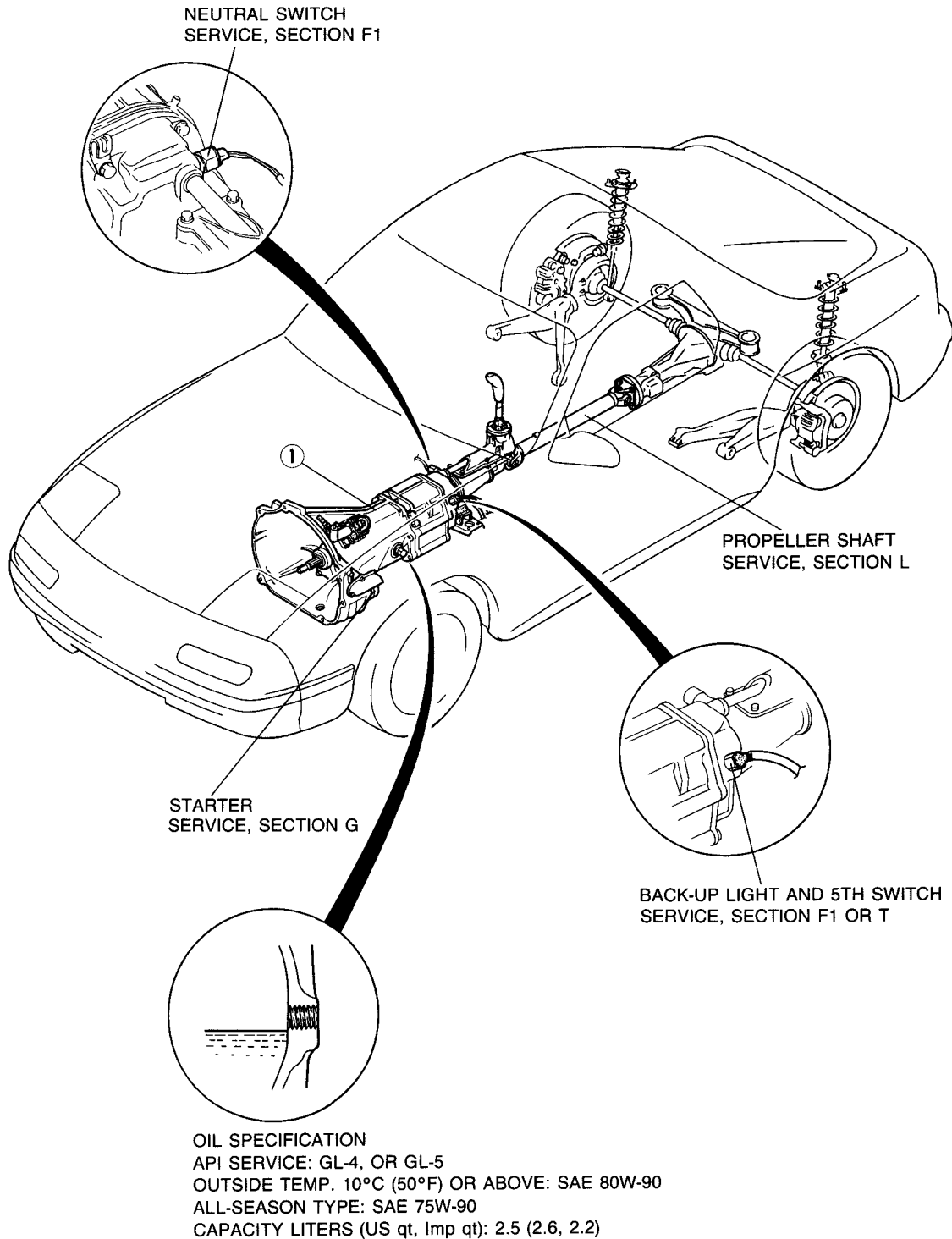

INDEX



97U0J1-002

1. Transmission	
Removal	page J1- 9
Disassembly	page J1-11

Inspection	page J1-21
Assembly	page J1-24
Installation	page J1-43

OUTLINE

SPECIFICATIONS

Item		Transmission model	M-type
Synchronization mechanism			Forward: Synchromesh Reverse: Synchromesh
Shift type			5-speed, floor shift
Shift pattern			
Gear ratio	1st		3.475
	2nd		2.002
	3rd		1.366
	4th		1.000
	5th		0.697 *0.756
	Reverse		3.493
Oil	Grade		API service GL-4 or GL-5
	Viscosity	All-season	SAE 75W-90
		Above 10°C (50°F)	SAE 80W-90
	Capacity	liters (US qts, Imp qts)	2.5 (2.6, 2.2)

* With viscous limited slip differential

97U0J1-003

STRUCTURAL VIEW

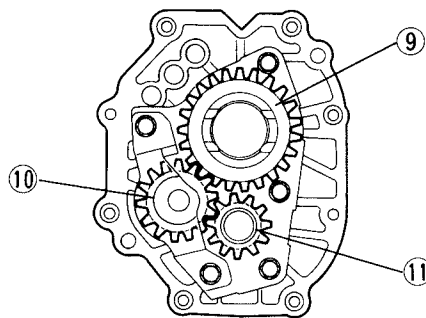
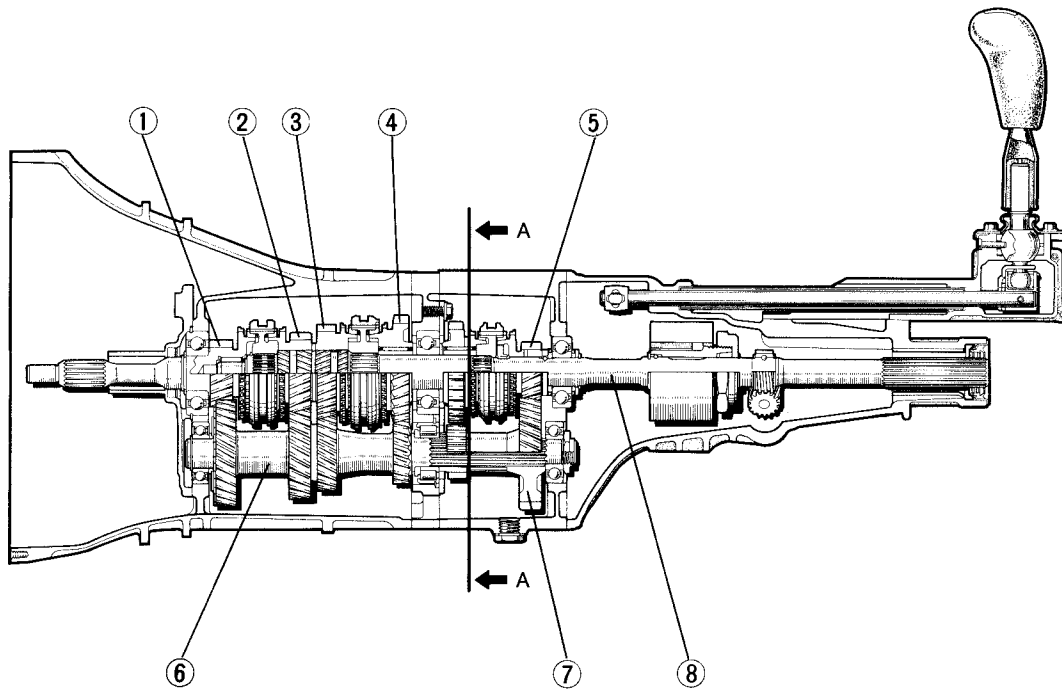

VIEW A—A

9MU0JX-004

- 1. Main drive gear (4th gear)
- 2. 3rd gear
- 3. 2nd gear
- 4. 1st gear
- 5. 5th gear
- 6. Countershaft

- 7. Counter 5th gear
- 8. Mainshaft
- 9. Reverse gear
- 10. Reverse idler gear
- 11. Counter reverse gear

POWERFLOW

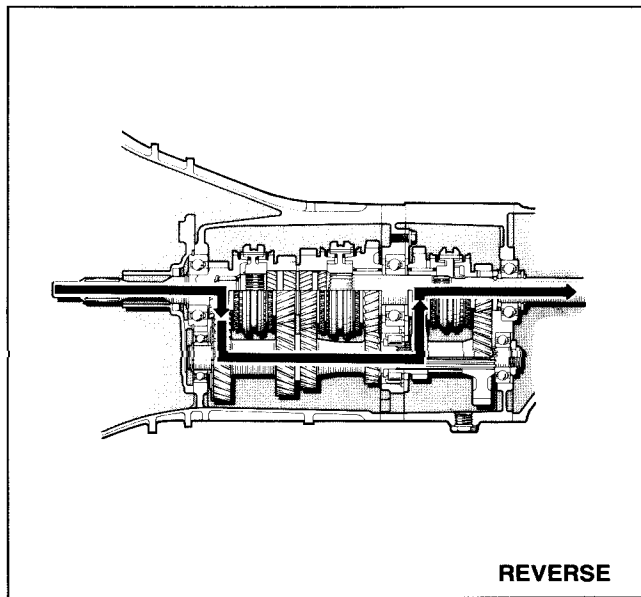
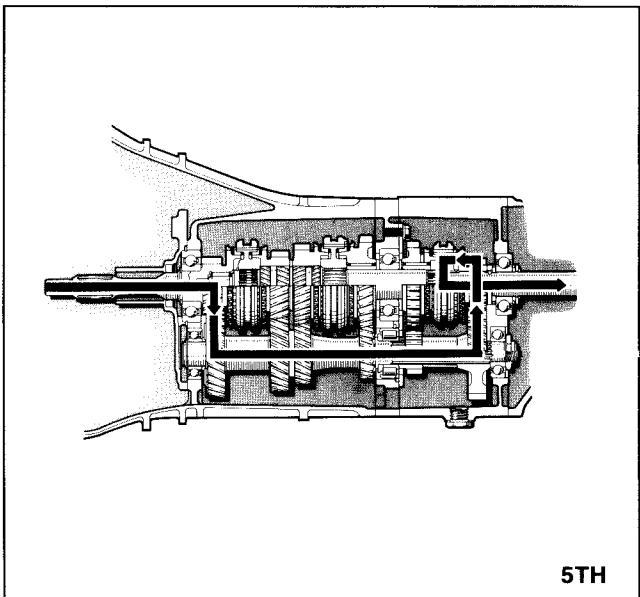
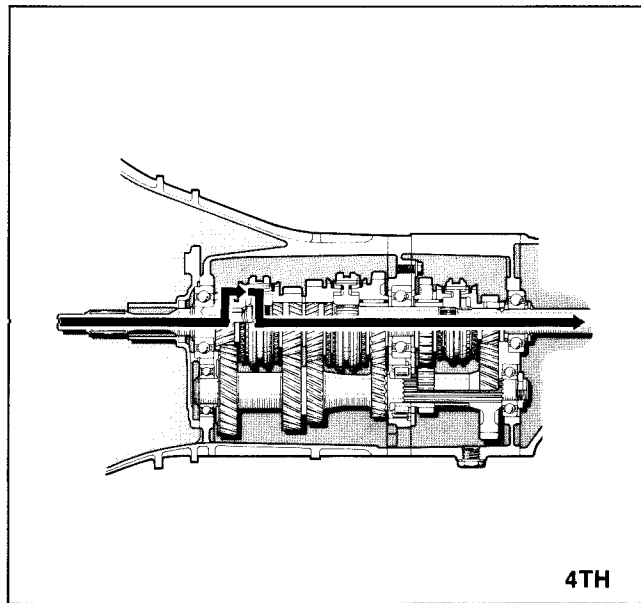
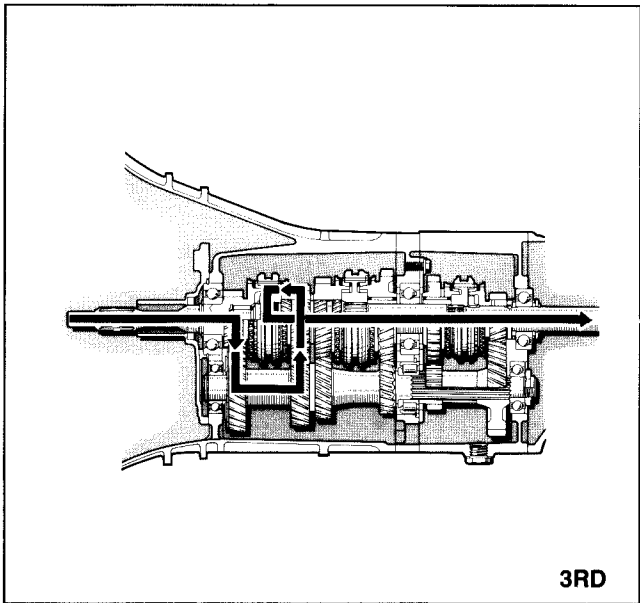
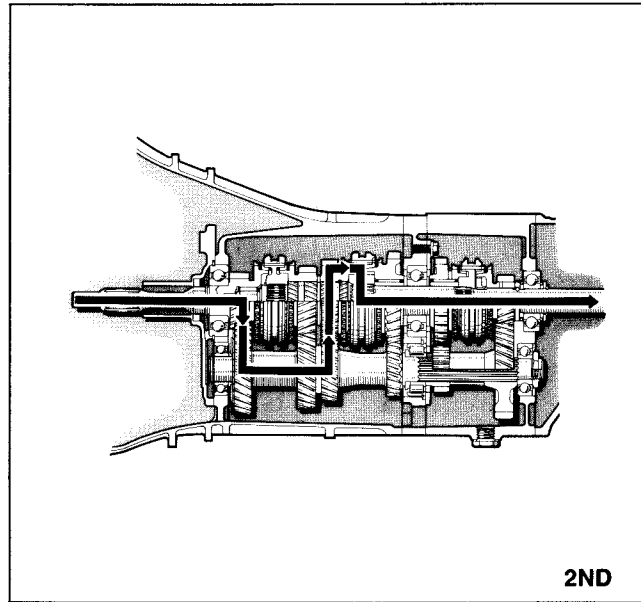
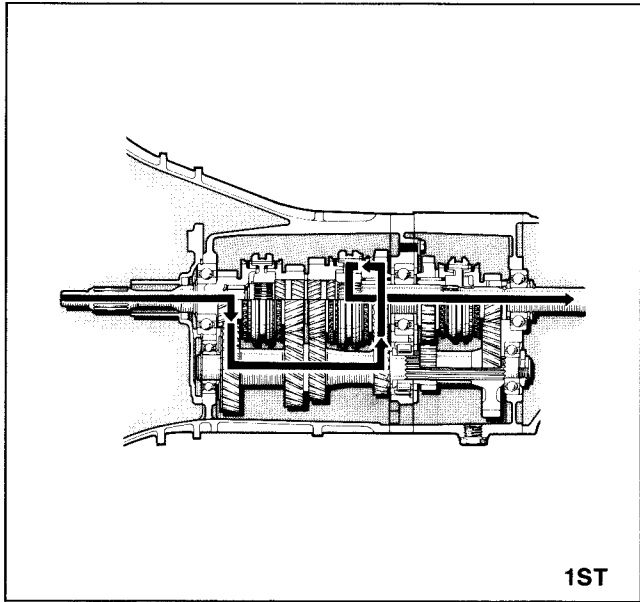

J1 TROUBLESHOOTING GUIDE

TROUBLESHOOTING GUIDE

Problem	Possible Cause	Action	Page
Abnormal noise	Insufficient oil	Add oil	J1- 7
	Deterioration of oil quality	Replace with specified oil	J1- 7
	Worn bearing	Replace	J1-23
	Worn contact surface of countershaft gear	Replace	J1-22
	Worn contact surface of gears	Replace	J1-21
	Excessive gear backlash	Replace	—
	Damaged gear teeth	Replace	J1-21
Difficult to shift	Insufficient oil	Add oil	J1- 7
	Deterioration of oil quality	Replace with specified oil	J1- 7
	Worn synchronizer ring	Replace	J1-22
	Worn synchronizer cone of gear	Replace	J1-22
	Poor contact of synchronizer ring and gear cone	Replace	J1-22
	Excessive longitudinal play of gears	Replace	J1-21
	Worn bearing	Replace	J1-23
Improper disengagement of clutch	Refer to Section H	—	
Jumps out of gear	Weak detent ball spring	Replace	J1-23
	Worn shift fork	Replace	J1-22
	Worn clutch hub	Replace	J1-22
	Worn clutch hub sleeve	Replace	J1-22
	Worn gears	Replace	J1-21
	Excessive gear backlash	Replace	—
	Worn bearing	Replace	J1-23
	Incorrect installation or loose engine mounts or transmission mounts	Tighten	J1-43

97U0J1-004

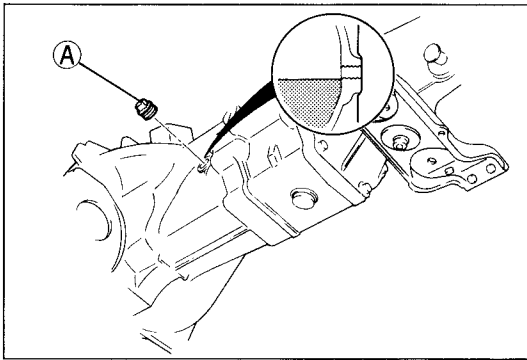

9BU0J1-005

TRANSMISSION OIL

INSPECTION

1. Remove check plug (A).
2. Verify that the oil is at the bottom of the check plug hole. If it is low, add the specified oil from check plug (A).
3. Apply sealant to the plug threads before installing.

Tightening torque:

(A): 25—39 N·m (2.5—4.0 m·kg, 18—29 ft·lb)

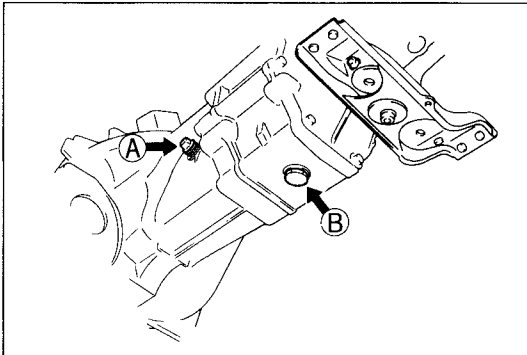

9BU0J1-006

REPLACEMENT

Note

Replace drain plug (B) washer with a new one whenever removed.

1. Remove the plugs (A) and (B) with washer.
2. Drain the oil into a suitable container.
3. Wipe all plugs clean.
4. Apply sealant to plug thread (A).
5. Install the drain plug (B) with new washer.

Tightening torque:

(B): 39—59 N·m (4.0—6.0 m·kg, 29—43 ft·lb)

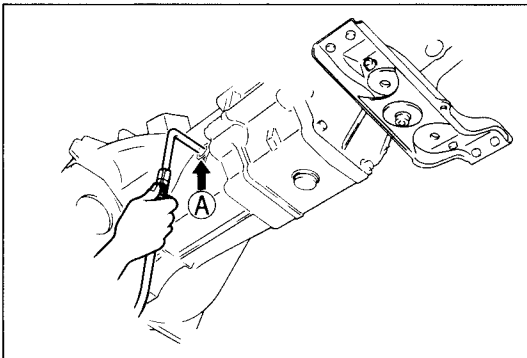

9BU0J1-007

6. Add the specified oil from check plug (A) port until the level reaches the bottom of check plug hole.

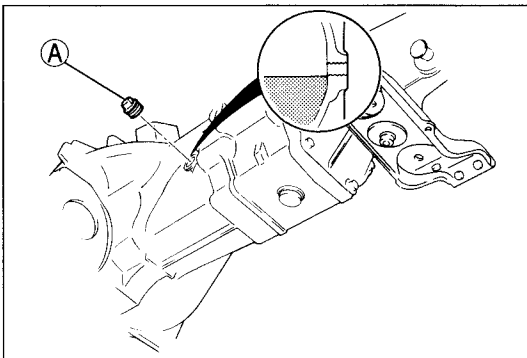

9BU0J1-008

7. Install plug (A).





Tightening torque:

(A): 25—39 N·m (2.5—4.0 m·kg, 18—29 ft·lb)

J1 TRANSMISSION

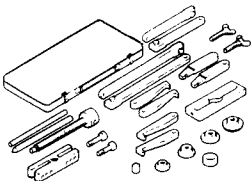
TRANSMISSION

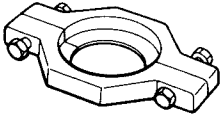
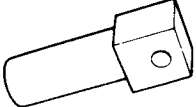
PREPARATION SST

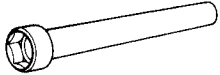
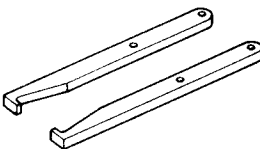
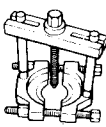
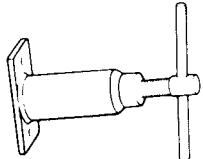
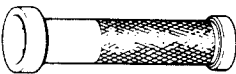
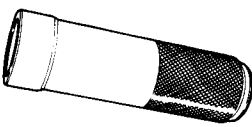
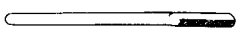
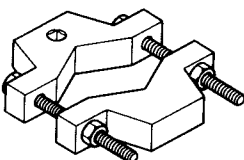
<p>49 0839 425C</p> <p>Puller set, bearing</p> 	<p>49 0500 330</p> <p>Installer, transmission bearing</p> 	<p>49 0636 145</p> <p>Puller, fan pulley boss</p> 
<p>49 0259 440</p> <p>Holder, main-shaft</p> 	<p>49 0862 350</p> <p>Guide, shift fork</p> 	<p>49 1243 465A</p> <p>Wrench, main-shaft locknut</p> 
<p>49 H017 101</p> <p>Hook</p> 	<p>49 0710 520</p> <p>Puller, bearing</p> 	<p>49 0305 430</p> <p>Pusher, main drive shaft</p> 
<p>49 0180 321A</p> <p>Installer, bearing</p> 	<p>49 F401 331</p> <p>Body</p> 	<p>49 0187 451A</p> <p>Guide, interlock pin</p> 
<p>49 F017 1A0</p> <p>Wrench</p> 	<p style="text-align: right;">97U0J1-005</p>	

REMOVAL

1. Disconnect the negative battery cable.
2. Raise the vehicle and support it with safety stands.
3. Drain the transmission oil into a suitable container.
4. Remove in the order shown in the figure, referring to **Removal Note**.

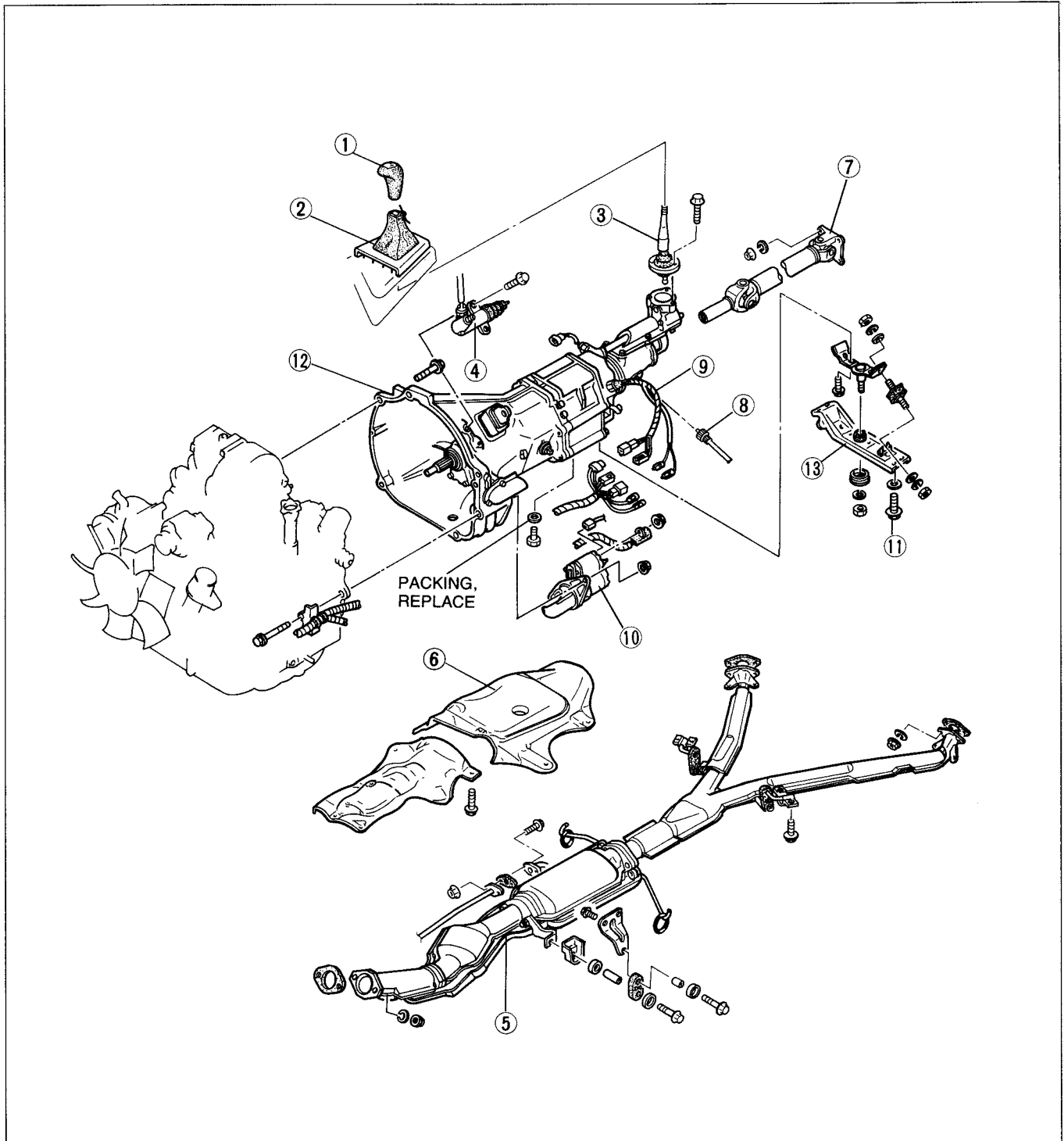

97U0J1-006

- | | | |
|---------------------------------------|--------------------------|------------------------------|
| 1. Change lever knob | 6. Heat insulator | 11. Transmission mount bolts |
| 2. Boot panel assembly and boot sheet | 7. Propeller shaft | 12. Transmission |
| 3. Shift lever | Removal page J1-10 | Disassembly ... page J1-11 |
| 4. Clutch release cylinder | 8. Speedometer cable | Inspection page J1-21 |
| Removal page J1-10 | 9. Connectors | Assembly page J1-24 |
| 5. Exhaust pipe | 10. Starter | 13. Transmission mount |

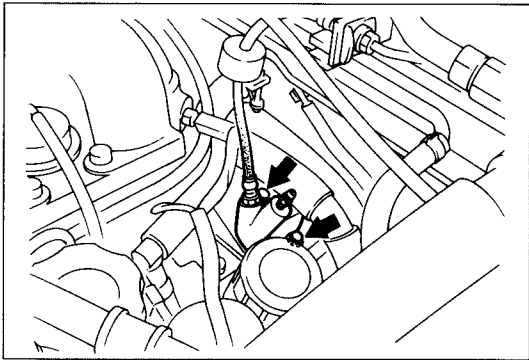

97U0J1-007

Removal note Clutch release cylinder

Remove the clutch release cylinder with the flexible hose still connected.

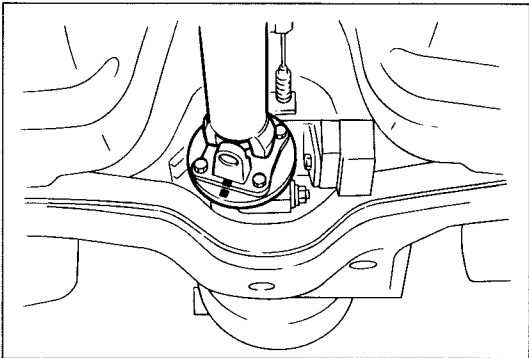

97U0J1-008

Propeller shaft

1. Before removing the propeller shaft, mark the flanges for correct reassembly.

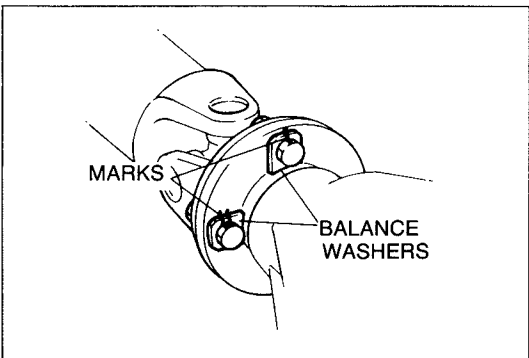

97U0J1-009

2. Mark the balance washers for correct reassembly.

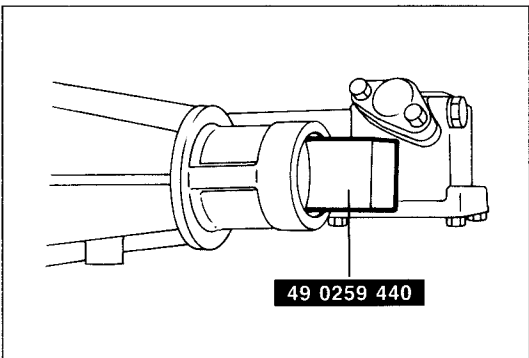

9MU0JX-017

3. When the propeller shaft is removed from the extension housing, install the **SST** into the extension housing.

DISASSEMBLY

Precaution

1. Clean the transmission exterior thoroughly with steam or cleaning solvents or both, before disassembly.
2. Clean the removed parts with cleaning solvent, and dry with compressed air. (Except sealed bearings.)
Clean out all holes and passages with a compressed air, and check that there are no obstructions.
3. Wear eye protection when using compressed air to clean components.

Housing Components

Disassemble in the order shown in the figure, referring to **Disassembly Note**.

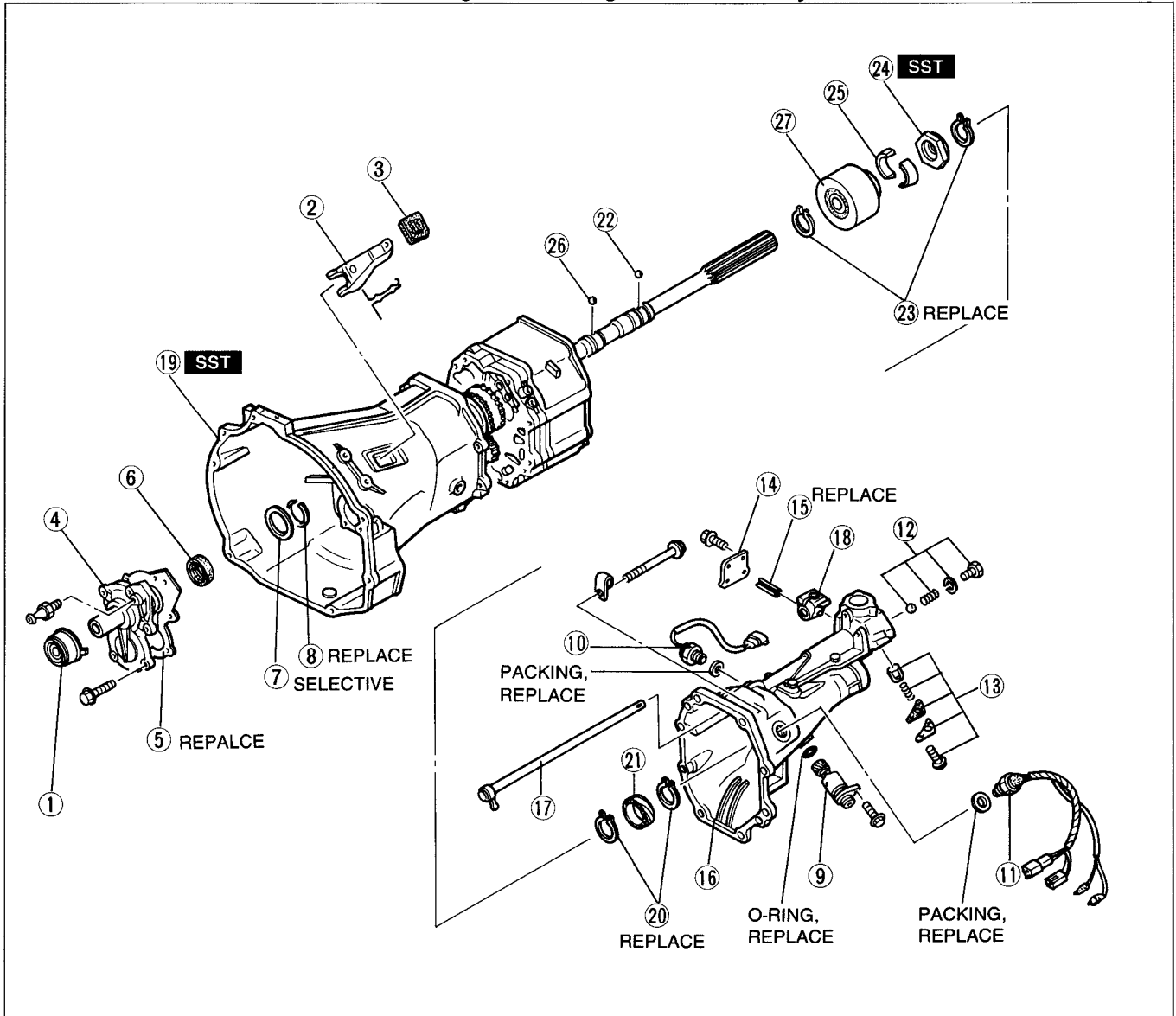

97U0J1-010

- | | | |
|---|---|-----------------------------|
| 1. Release bearing | 10. Neutral switch | 18. Control lever end |
| 2. Release fork | 11. Back-up light and 5th switch | 19. Transmission case |
| 3. Boot | 12. Steel ball, spring, and spring cap | Removal page J1-12 |
| 4. Front cover | 13. Select-lock spindle, spring, and spring cap | 20. Snap rings |
| 5. Gasket | 14. Blind cover | 21. Speedometer driven gear |
| 6. Oil seal | 15. Roll pin | 22. Steel ball |
| Inspect for damage of oil seal lip. If necessary, replace it. | 16. Extension housing | 23. Snap rings |
| 7. Adjustment shim | Removal page J1-12 | 24. Locknut |
| 8. Snap ring | Disassembly ... page J1-20 | Removal page J1-12 |
| 9. Speedometer drive gear | 17. Control lever | 25. Taper cotter |
| | | 26. Steel ball |
| | | 27. Dynamic damper |

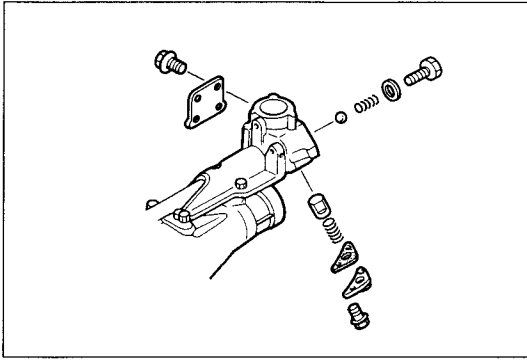

97U0J1-011

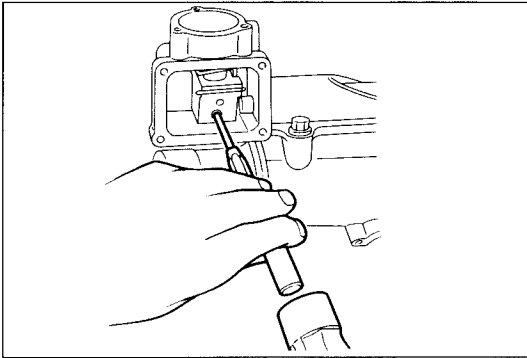

97U0J1-012

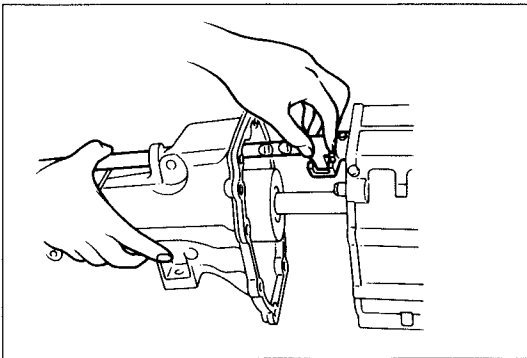

97U0J1-013

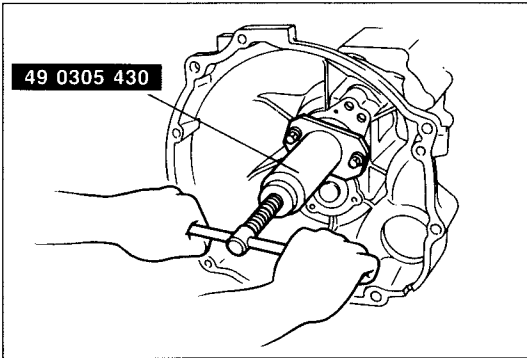

9BU0J1-013

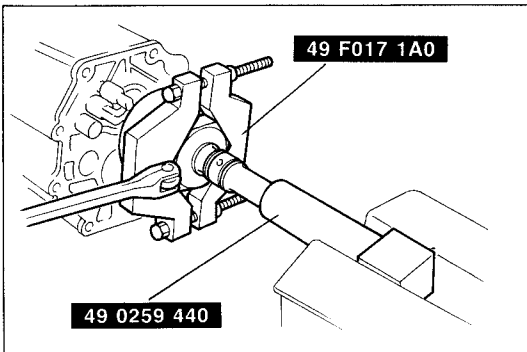

97U0J1-014

Disassembly note

Extension housing

1. Remove the spring cap, spring, and steel ball.
2. Remove the spring cap, spring, and select-lock spindle.
3. Remove the blind cover.

4. Drive the roll pin from the control lever end.

Note

Do not remove the change control case.

5. Remove the extension housing attaching bolts.
6. Remove the extension housing.

Transmission case

Remove the transmission case from the intermediate housing and gear assembly with the **SST**.

Locknut

Note

Use pads in the vise to prevent damaging the SST.

1. Connect the **SST** to the mainshaft and tighten it securely in a vise.
2. Remove the locknut with the **SST**.

Shift Fork and Shift Rod Parts

Disassemble in the order shown in the figure, referring to **Disassembly Note**.

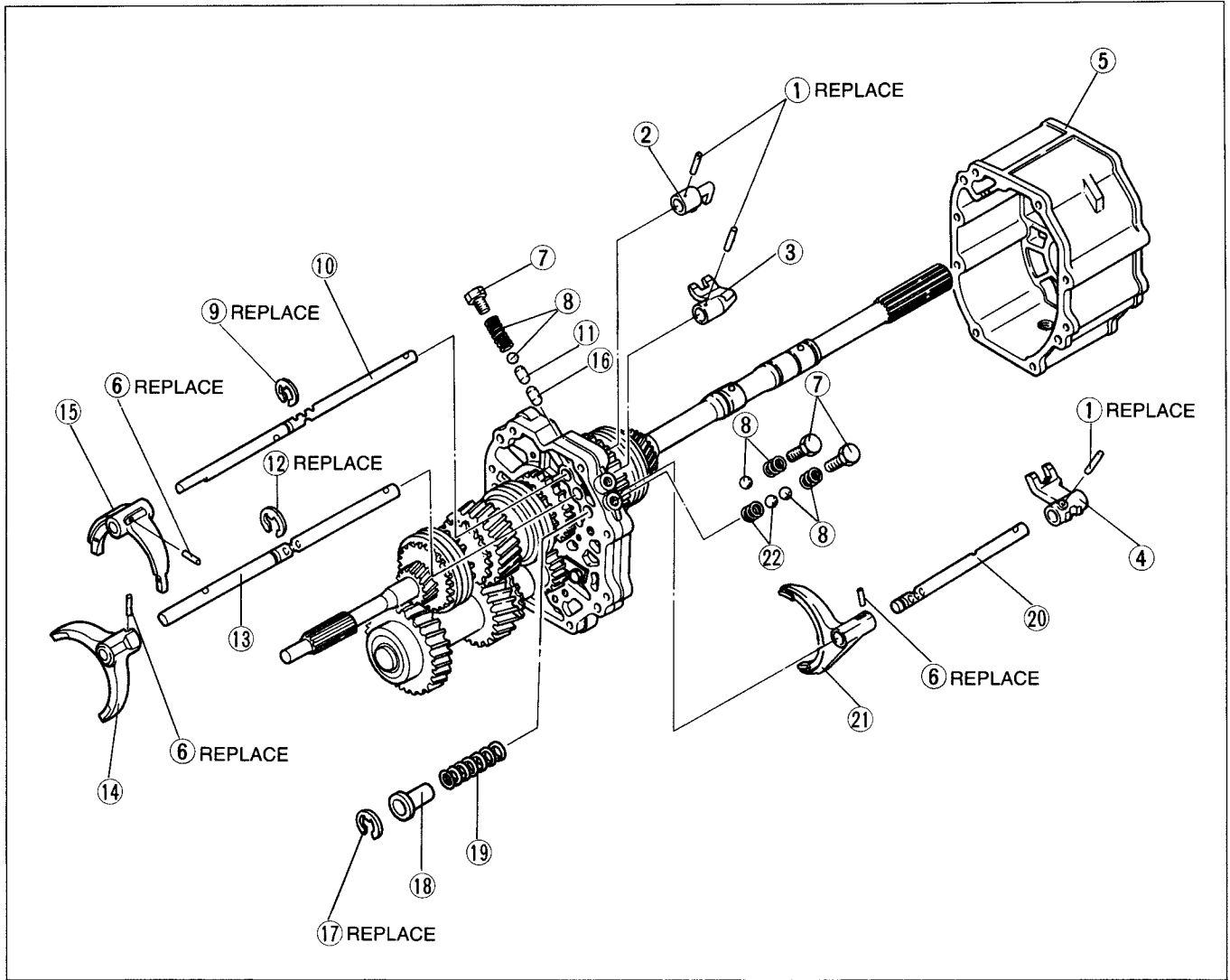

97U0J1-015

- | | | |
|------------------------------|-----------------------------|-----------------------------|
| 1. Roll pin | 9. Clip | 17. Clip |
| 2. 1st/2nd shift rod end | 10. 1st/2nd shift rod | Removal page J1-13 |
| 3. 3rd/4th shift rod end | 11. Interlock pin | 18. Spacer |
| 4. 5th/Reverse shift rod end | 12. Clip | 19. Spring |
| 5. Intermediate housing | 13. 3rd/4th shift rod | Inspection page J1-23 |
| Inspection page J1-23 | 14. 3rd/4th shift fork | 20. 5th/Reverse shift rod |
| 6. Roll pin | Inspection page J1-22 | 21. 5th/Reverse shift fork |
| 7. Cap plug | 15. 1st/2nd shift fork | Inspection page J1-22 |
| 8. Spring and ball | Inspection page J1-23 | 22. Spring and ball |
| Inspection page J1-23 | 16. Interlock pin | Inspection page J1-23 |

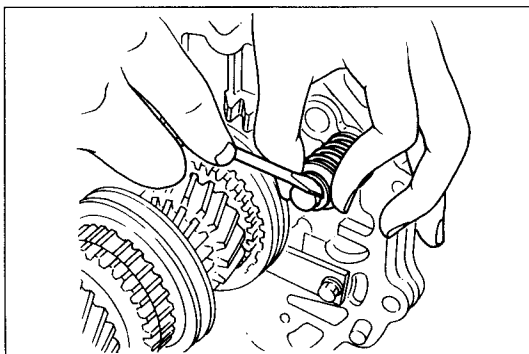

97U0J1-016

Disassembly note Clip

Caution

Hold the spacer and spring with your fingers to prevent it from jumping out.

Remove the clip, spacer, and spring from the 5th/Reverse shift rod.

J1 TRANSMISSION

Mainshaft and Countershaft Parts

Disassemble in the order shown in the figure, referring to **Disassembly Note**.

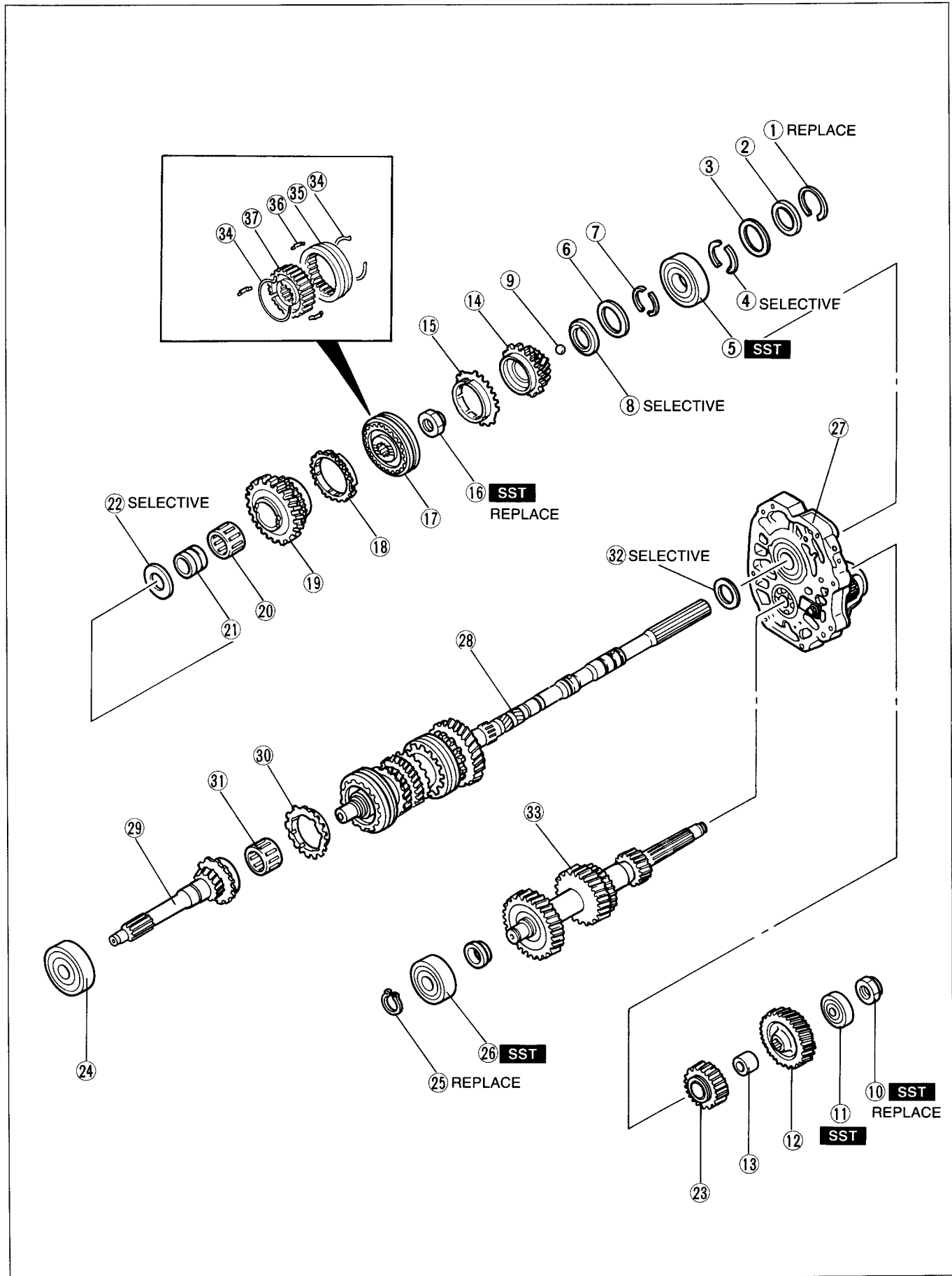

- | | | |
|--|---|--|
| 1. Snap ring | 15. Synchronizer ring (5th)
Inspection page J1-22 | 26. Countershaft front bearing
Removal page J1-16 |
| 2. Washer | 16. Locknut (Mainshaft)
Removal page J1-16 | Inspection page J1-23 |
| 3. Retaining ring | 17. Clutch hub assembly
(5th/Reverse)
Inspection page J1-22 | 27. Bearing housing assembly
Removal page J1-16 |
| 4. C-washer | 18. Synchronizer ring (Reverse)
Inspection page J1-22 | Disassembly ... page J1-18 |
| 5. Mainshaft rear bearing
Removal page J1-15
Inspection page J1-23 | 19. Reverse gear
Inspection page J1-21 | 28. Mainshaft gear assembly |
| 6. Retaining ring | 20. Needle bearing
Inspection page J1-23 | 29. Main drive gear
Inspection page J1-21 |
| 7. C-washer | 21. Inner race | 30. Synchronizer ring (4th)
Inspection page J1-22 |
| 8. Thrust lock washer | 22. Washer | 31. Needle bearing
Inspection page J1-23 |
| 9. Steel ball | 23. Counter reverse gear
Inspection page J1-21 | 32. Washer |
| 10. Locknut (Countershaft)
Removal page J1-15 | 24. Main drive gear bearing
Removal page J1-16 | 33. Countershaft
Inspection page J1-22 |
| 11. Countershaft rear bearing
Removal page J1-16
Inspection page J1-23 | 25. Snap ring | 34. Synchronizer key spring |
| 12. Counter 5th gear
Inspection page J1-21 | | 35. Clutch hub sleeve |
| 13. Spacer | | 36. Synchronizer key |
| 14. 5th gear
Inspection page J1-21 | | 37. Clutch hub |

97U0J1-018

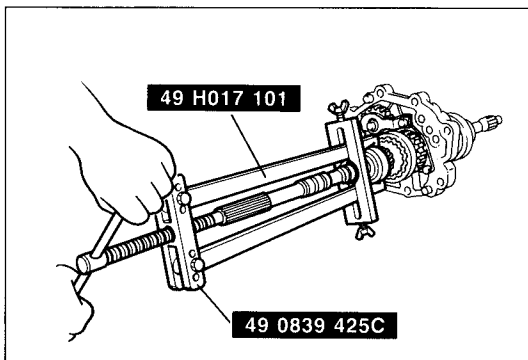

97U0J1-019

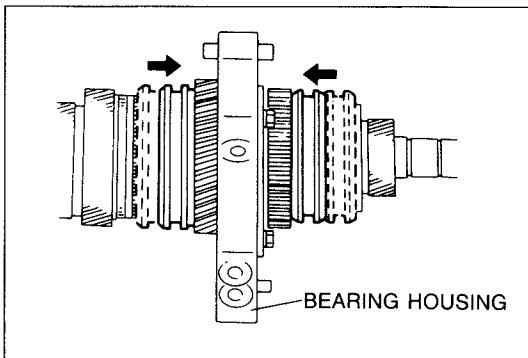

97U0J1-020

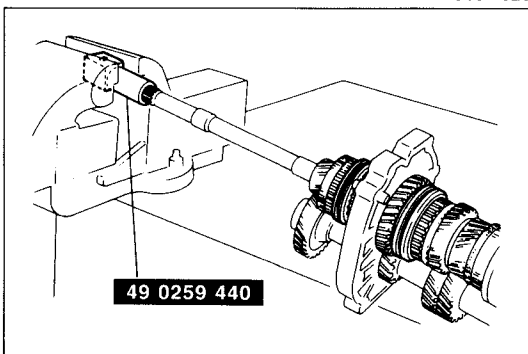

97U0J1-021

Disassembly note

Mainshaft rear bearing

Remove the snap ring, washer, retaining ring, and C-washers; then remove the mainshaft rear bearing with the **SST**.

Locknut (Countershaft)

1. Shift the clutch hub sleeves to first gear and reverse gear to put the gears in the double-engaged condition.

Caution

- a) Do not reuse the locknut.
- b) Do not damage the countershaft.

2. Use a suitable tool to uncrimp the tabs of the locknut.

Note

Use pads in the vise to prevent damaging the **SST**.

3. Connect the **SST** to the mainshaft and tighten it securely in a vise.
4. Remove the locknut.

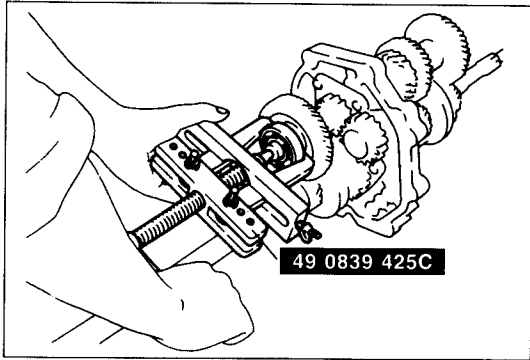

97U0J1-022

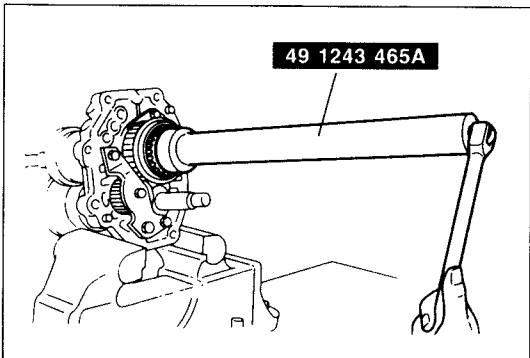

97U0J1-023

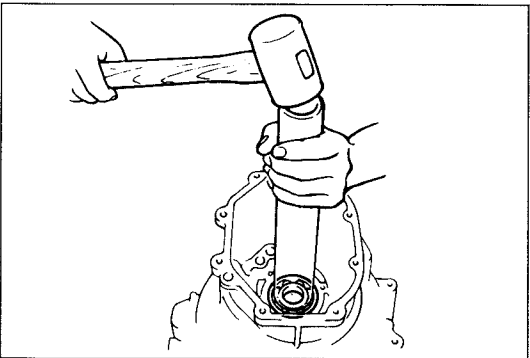

97U0J1-024

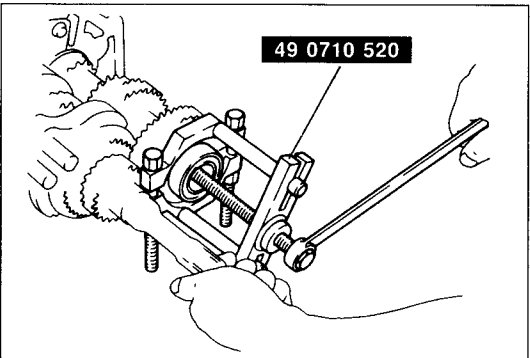

97U0J1-025

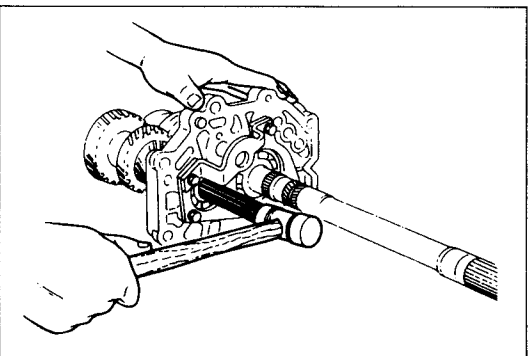

97U0J1-026

Countershaft rear bearing

Remove the countershaft rear bearing with the **SST**.

Locknut (Mainshaft)

1. Shift the clutch hub sleeves to first gear and reverse gear to put the gears in the double-engaged condition.

Caution

- a) Do not reuse the locknut.
- b) Do not damage the mainshaft.

2. Use a suitable tool to uncrimp the tabs of the locknut.

Note

Use pads in the vise to prevent damaging the bearing housing.

3. Secure the bearing housing in a vise.

4. Remove the locknut with the **SST**.

Main drive gear bearing

Remove the main drive gear bearing with a suitable pipe.

Countershaft front bearing

Remove the countershaft front bearing with the **SST**.

Bearing housing assembly

Remove the bearing housing by lightly tapping the countershaft with a copper hammer.

Mainshaft Parts

Disassemble in the order shown in the figure, referring to **Disassembly Note**.

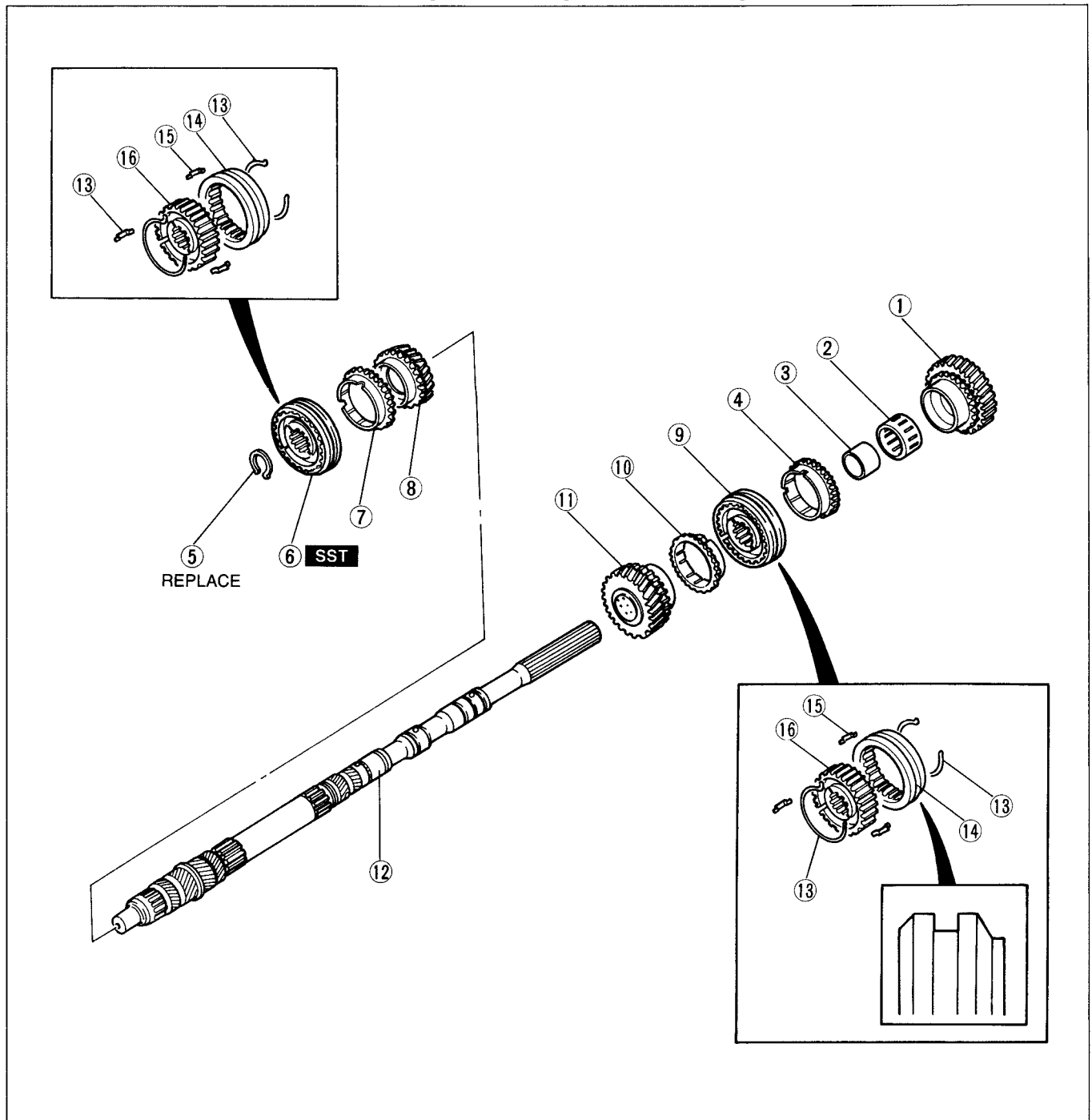

97U0J1-027

- | | | |
|--|--|--|
| 1. 1st gear
Inspection page J1-21 | 7. Synchronizer ring (3rd)
Inspection page J1-22 | 12. Mainshaft
Inspection page J1-21 |
| 2. Needle bearing
Inspection page J1-23 | 8. 3rd gear
Inspection page J1-21 | 13. Synchronizer key spring |
| 3. Inner race | 9. Clutch hub assembly
(1st/2nd)
Removal page J1-18
Inspection page J1-22 | 14. Clutch hub sleeve |
| 4. Synchronizer ring (1st)
Inspection page J1-22 | 10. Synchronizer ring (2nd)
Inspection page J1-22 | 15. Synchronizer key |
| 5. Snap ring | 11. 2nd gear
Inspection page J1-21 | 16. Clutch hub |
| 6. Clutch hub assembly
(3rd/4th)
Removal page J1-18
Inspection page J1-22 | | |

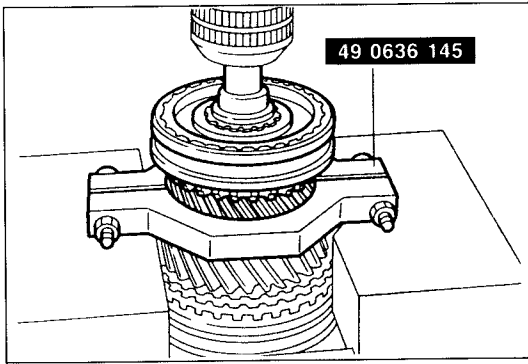

97U0J1-028

Disassembly note Clutch hub assembly (3rd/4th)

1. Position the **SST** between 2nd and 3rd gears.

Caution

Hold the mainshaft with one hand so that it does not fall.

2. Press the mainshaft out of clutch hub assembly (3rd/4th) and 3rd gear.

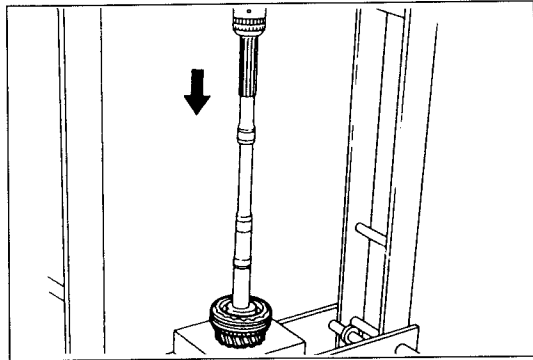

97U0J1-029

Clutch hub assembly (1st/2nd)

Caution

Hold the mainshaft with one hand so that it does not fall.

- Press the mainshaft out of clutch hub assembly (1st/2nd) and 2nd gear.

Bearing Housing Parts

Disassemble in the order shown in the figure, referring to **Disassembly Note**.

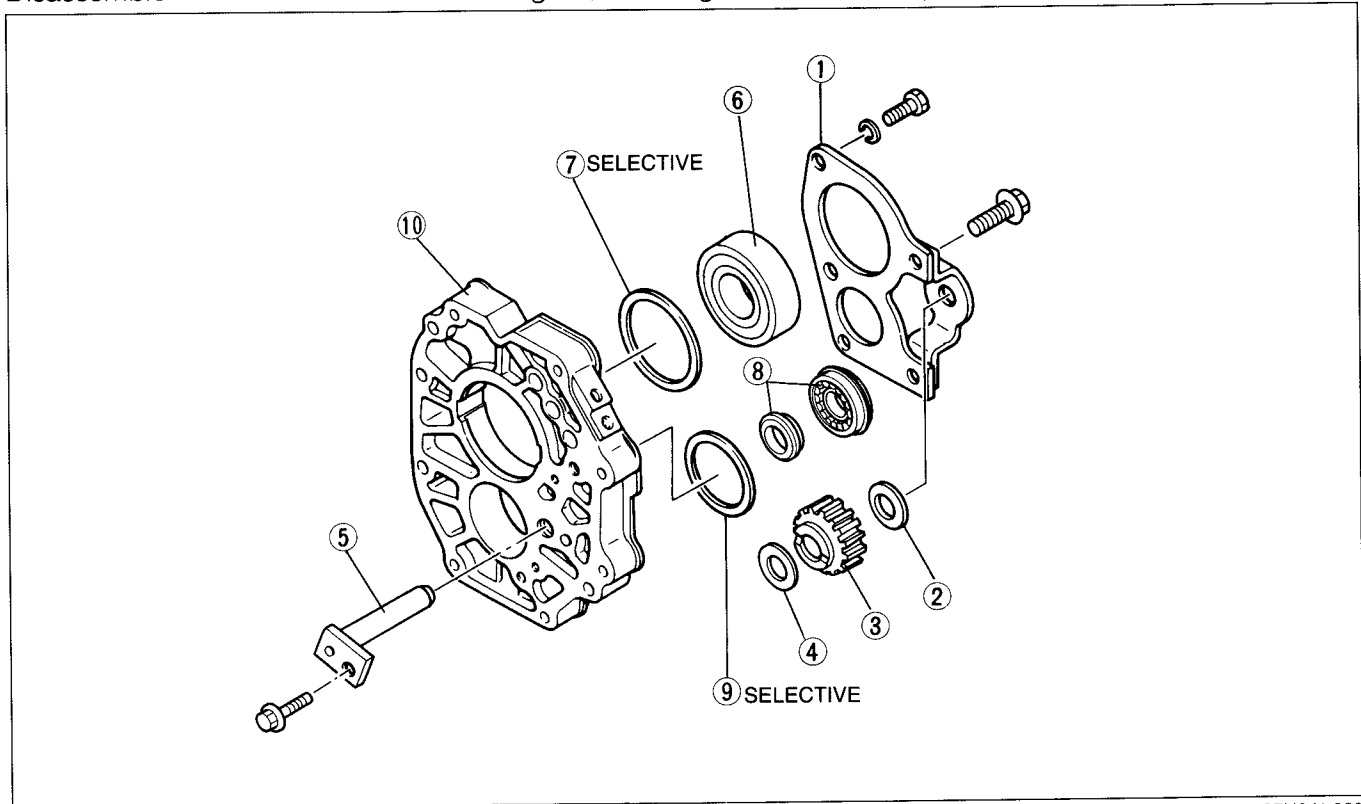

97U0J1-030

- | | | |
|-----------------------------|-----------------------------|--------------------------------|
| 1. Bearing cover | 5. Reverse idler gear shaft | 7. Adjustment shim |
| 2. Washer | Removal page J1-19 | 8. Countershaft center bearing |
| 3. Reverse idler gear | Inspection page J1-23 | Removal page J1-19 |
| Inspection page J1-23 | 6. Mainshaft front bearing | Inspection page J1-23 |
| 4. Washer | Removal page J1-19 | 9. Adjustment shim |
| | Inspection page J1-23 | 10. Bearing housing |

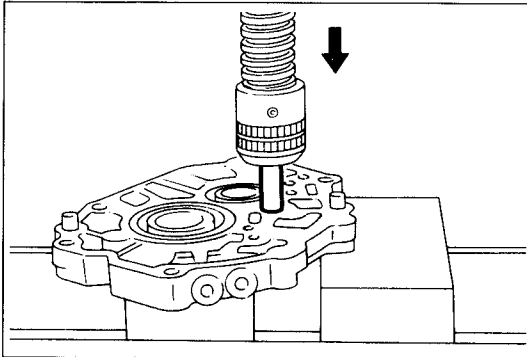

97U0J1-031

Disassembly note
Reverse idler gear shaft

Caution
Support the reverse idler gear shaft with one hand so that it does not fall.

Press the reverse idler gear shaft out of bearing housing.

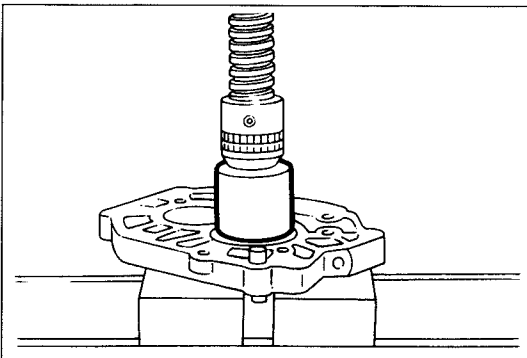

97U0J1-032

Mainshaft front bearing

Caution
Support the mainshaft front bearing with one hand so that it does not fall.

Remove the mainshaft front bearing with a suitable pipe.

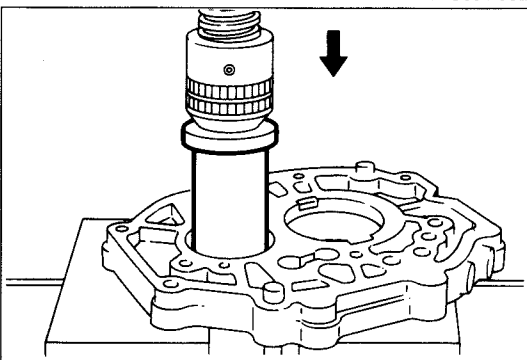

97U0J1-033

Countershaft center bearing

Caution
Support the countershaft center bearing with one hand so that it does not fall.

Note
If countershaft center bearing is replaced, replace the spacer also.

Remove the countershaft center bearing with a suitable pipe.

J1 TRANSMISSION

Extension Housing Parts

Disassemble in the order shown in the figure.

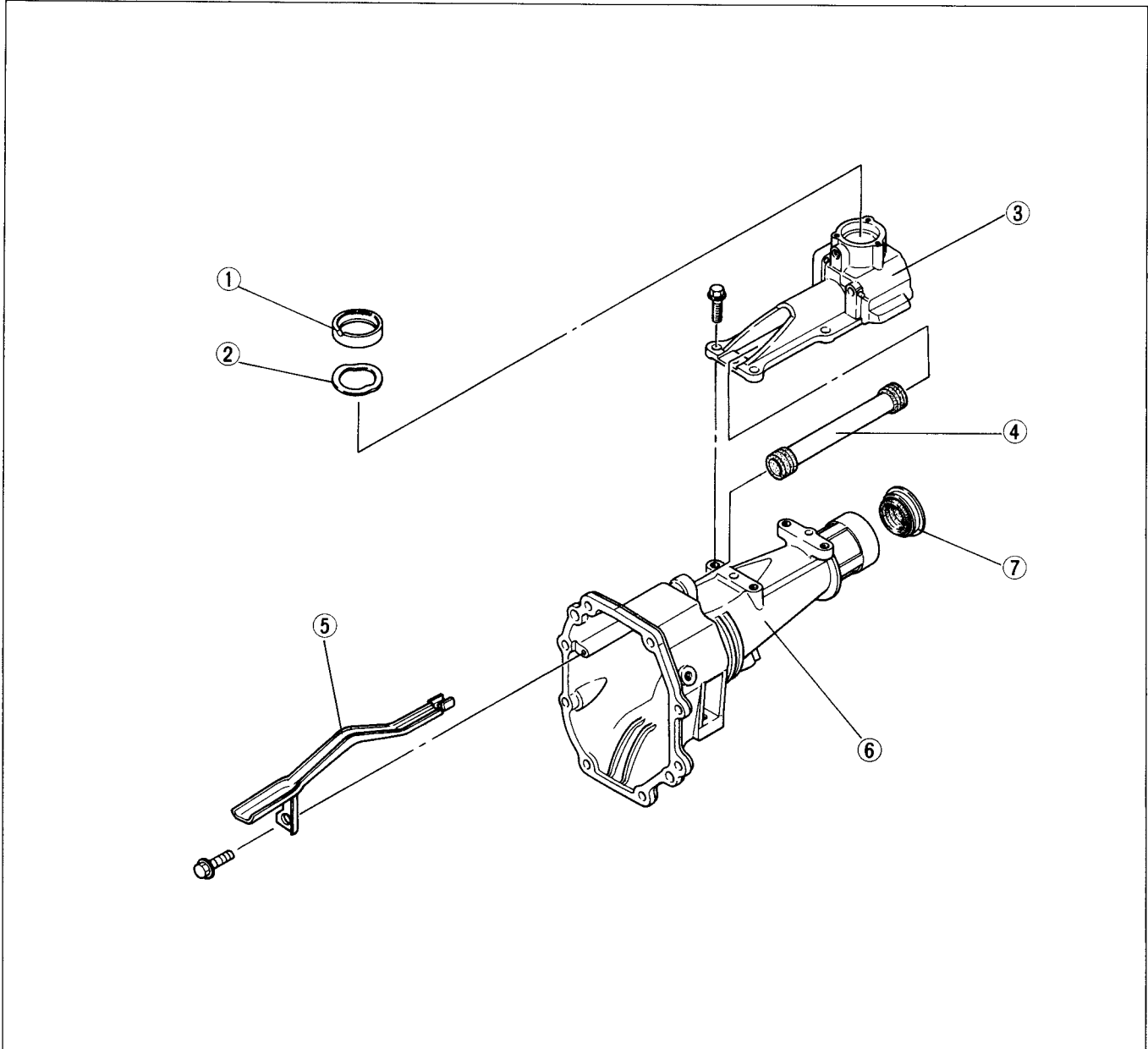

97U0J1-034

1. Change bush
2. Wave washer
3. Change control case

4. Rod cover
5. Oil passage
6. Extension housing

7. Oil seal
Do not remove if not necessary
Replace
(On-vehicle) .. page J1-20

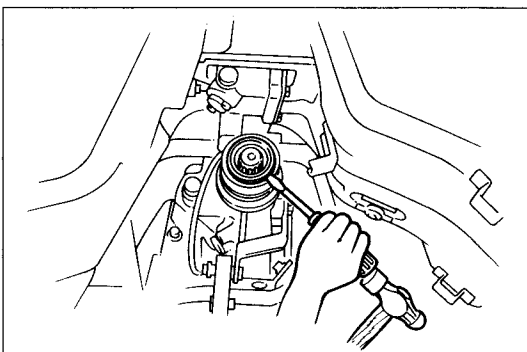

97U0J1-035

On-vehicle replacement Oil seal

Caution

Do not damage the mainshaft splines.

1. Remove the exhaust pipe and heat insulator.
(Refer to page J1-9.)
2. Remove the propeller shaft. (Refer to Section L)
3. Remove the oil seal from the extension housing.

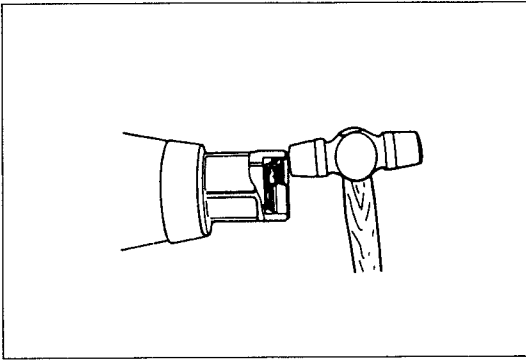

97U0J1-036

4. Apply transmission oil to outer periphery and lip surface.
5. Install the oil seal with a plastic hammer.

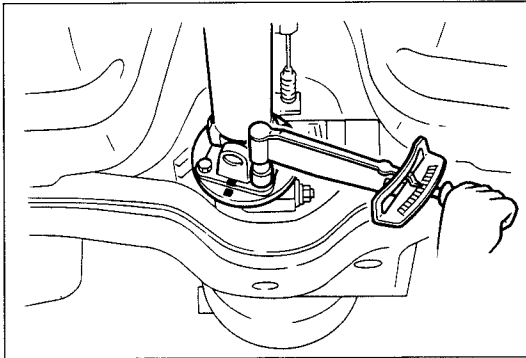

97U0J1-037

6. Install the propeller shaft. (Refer to Section L)
7. Install the heat insulator and exhaust pipe. (Refer to page J1-43.)

INSPECTION

Inspect all parts, and repair or replace as necessary.

9MU0JX-054

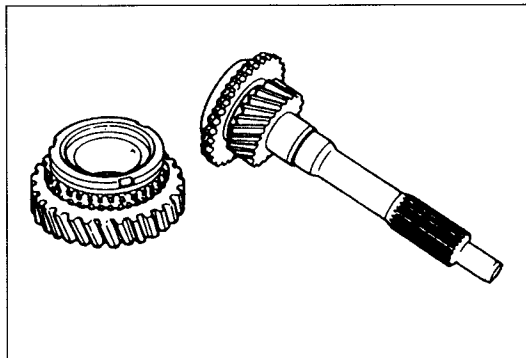

9MU0JX-055

Each gear and main drive gear

1. Inspect synchronizer cones for wear.
2. Inspect individual gear teeth for damage, wear, cracks.
3. Inspect synchronizer ring matching teeth for damage or wear.
4. Inspect main drive gear splines for damage or wear.

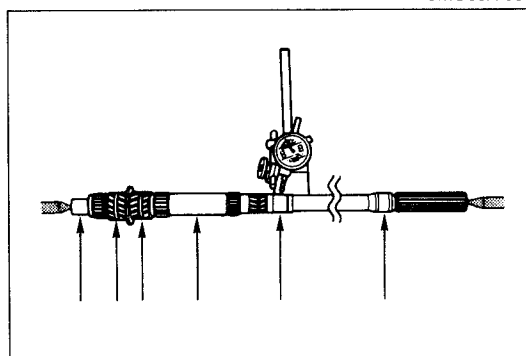

9MU0JX-056

Mainshaft

1. Measure the mainshaft runout.

Maximum: 0.03mm (0.0012 in)

2. Inspect splines for damage or wear.
3. Measure the clearance between mainshaft and gear (or bush).

Maximum: 0.15mm (0.006 in)

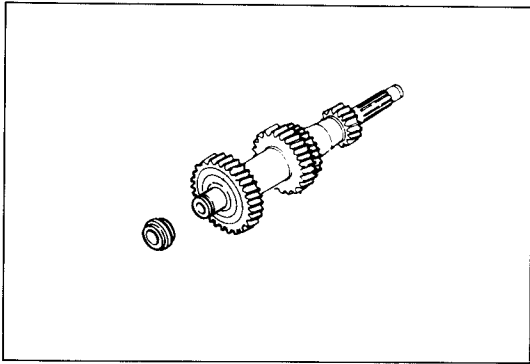

9MU0JX-057

Countershaft

1. Inspect gear teeth for damage, wear, cracks.
2. Inspect splines for damage or wear.

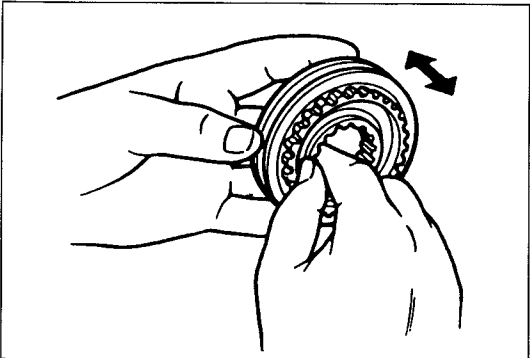

9MU0JX-059

Clutch hub assembly

1. Inspect for clutch hub sleeve and hub operation.
2. Inspect individual gear teeth for damage, wear, cracks.
3. Inspect synchronizer key for damage, wear, cracks.

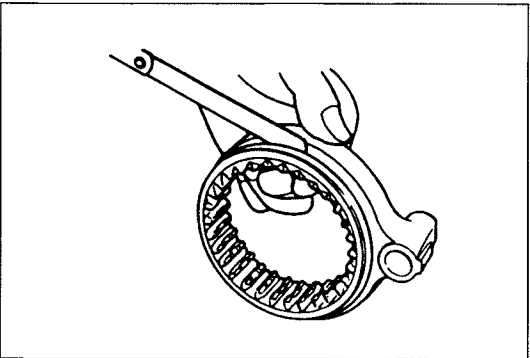

9MU0JX-060

4. Measure the clearance between hub sleeve and shift fork.

Standard clearance: 0.2—0.3mm (0.008—0.012 in)

Maximum: 0.5mm (0.020 in)

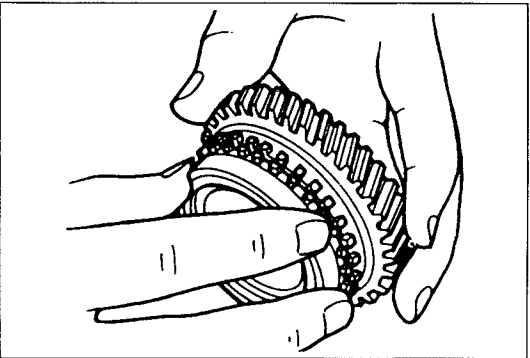

9MU0JX-061

Synchronizer ring

1. Inspect individual synchronizer ring teeth for damage, wear, cracks.
2. Inspect taper surface for wear or cracks.

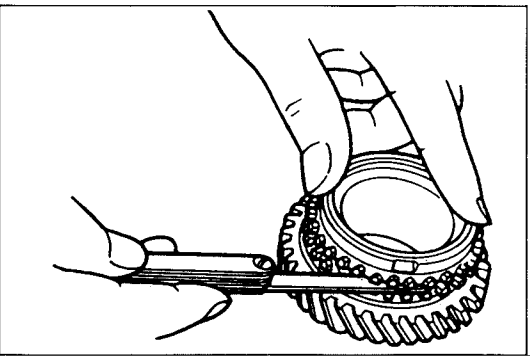

9MU0JX-062

Note

Set the synchronizer ring squarely in the gear; then measure around the circumference.

3. Measure the clearance between synchronizer ring and flank surface of gear.

Standard clearance: 1.5mm (0.059 in)

Minimum: 0.8mm (0.031 in)

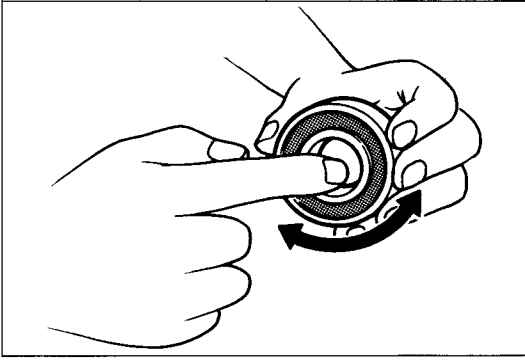

9MU0JX-063

Bearing

Inspect for damage or rough rotation.

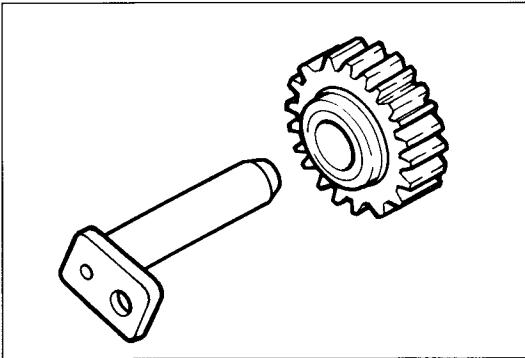

9MU0JX-064

Reverse idler gear and shaft

1. Inspect gear teeth for damage, wear, cracks.
2. Measure the clearance between reverse idle gear bush and shaft.

Standard clearance:

0.02—0.05mm (0.0008—0.0020 in)

Maximum: 0.15mm (0.006 in)

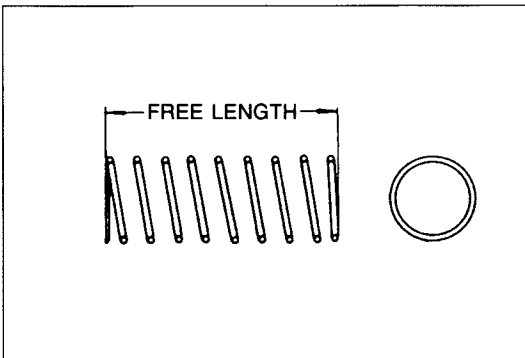

97U0J1-038

Springs

Measure the free length of spring.

Standard free length

Shift rod (5th/Reverse) spring: 75mm (2.953 in)

Detent ball spring (1st/2nd, 3rd/4th):

22.5mm (0.886 in)

Detent ball spring (5th/Reverse): 17.0mm (0.669 in)

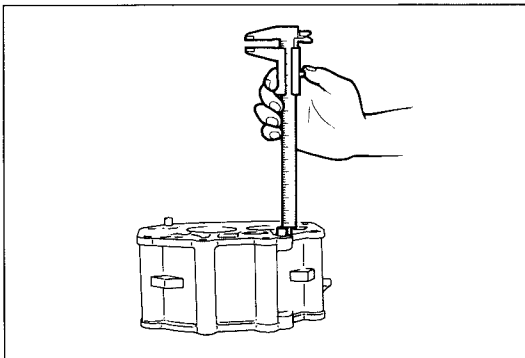

97U0J1-039

Intermediate housing

Measure the intermediate housing pin height.

Standard height: 9.0—10.0mm (0.354—0.394 in)

J1 TRANSMISSION

ASSEMBLY

Precaution

1. All O-rings and gasket must be replaced with the new ones included in the overhaul kit.
2. Assemble the parts within 10 minutes after applying sealant. Allow all sealant to cure at least 30 minutes after assembly before filling the transmission with transmission oil.

9MU0JX-066

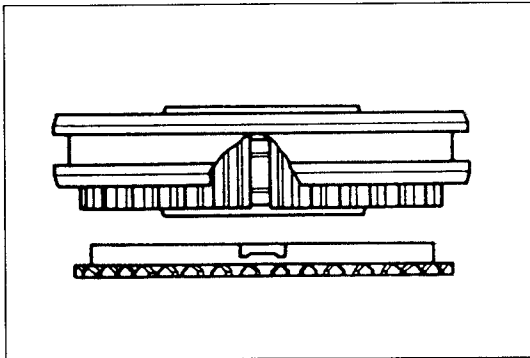

9MU0JX-067

Clutch hub

Caution

Align the synchronizer ring grooves with the clutch hub keys during installation.

Note

- a) The synchronizer rings all have the same basic shape. Carefully note these distinguishing features.
- 5th and Reverse synchronizer rings are the smallest.
 - Reverse has 2 notches in the teeth.
 - 4th and 3rd are the next larger and are exactly the same.
 - 2nd and 1st are the biggest and are exactly the same.

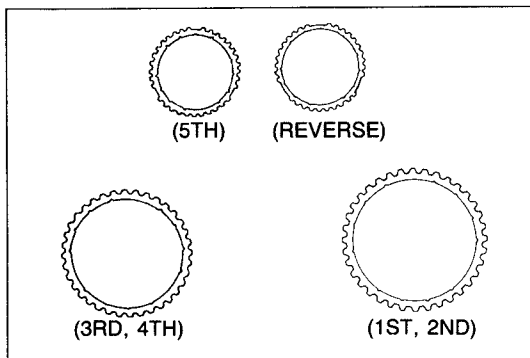

97U0J1-040

- b) Press each clutch hub assembly onto the mainshaft in the proper direction.
- c) Install the clutch hubs with the chamfers of the inner gear teeth as shown.

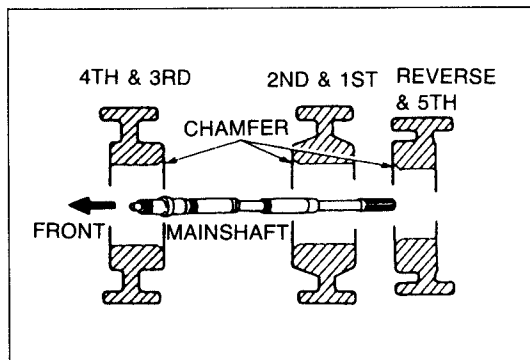

97U0J1-041

Extension Housing Parts

Assemble in the order shown in the figure, referring to **Assembly Note**.

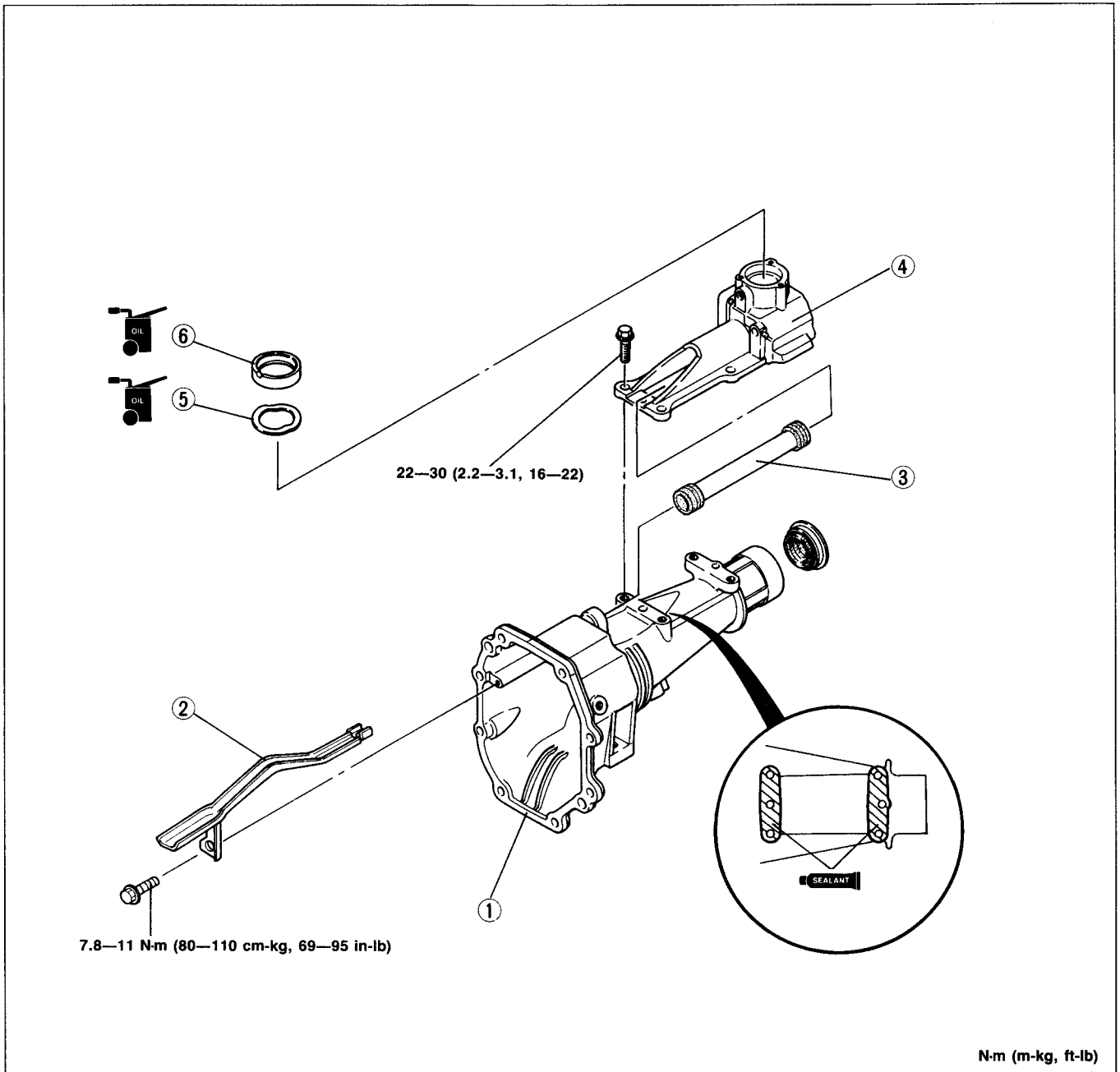

97U0J1-042

- 1. Extension housing
- 2. Oil passage
- 3. Rod cover

- 4. Change control case
Installation..... page J1-25
- 5. Wave washer

- 6. Change bush

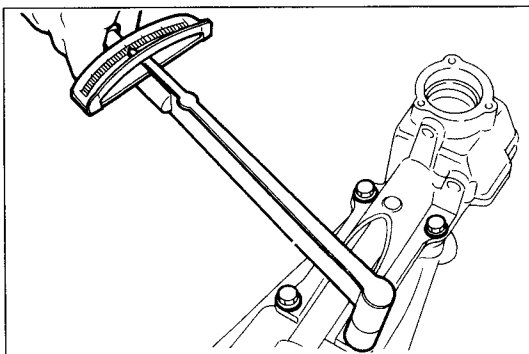

97U0J1-043

Assembly note

Change control case

1. Apply sealant to the contact surfaces of the change control case and extension housing.
2. Install the change control case.

Tightening torque:

22—30 N·m (2.2—3.1 m·kg, 16—22 ft·lb)

Bearing Housing Parts

Assemble in the order shown in the figure, referring to **Assembly Note**.

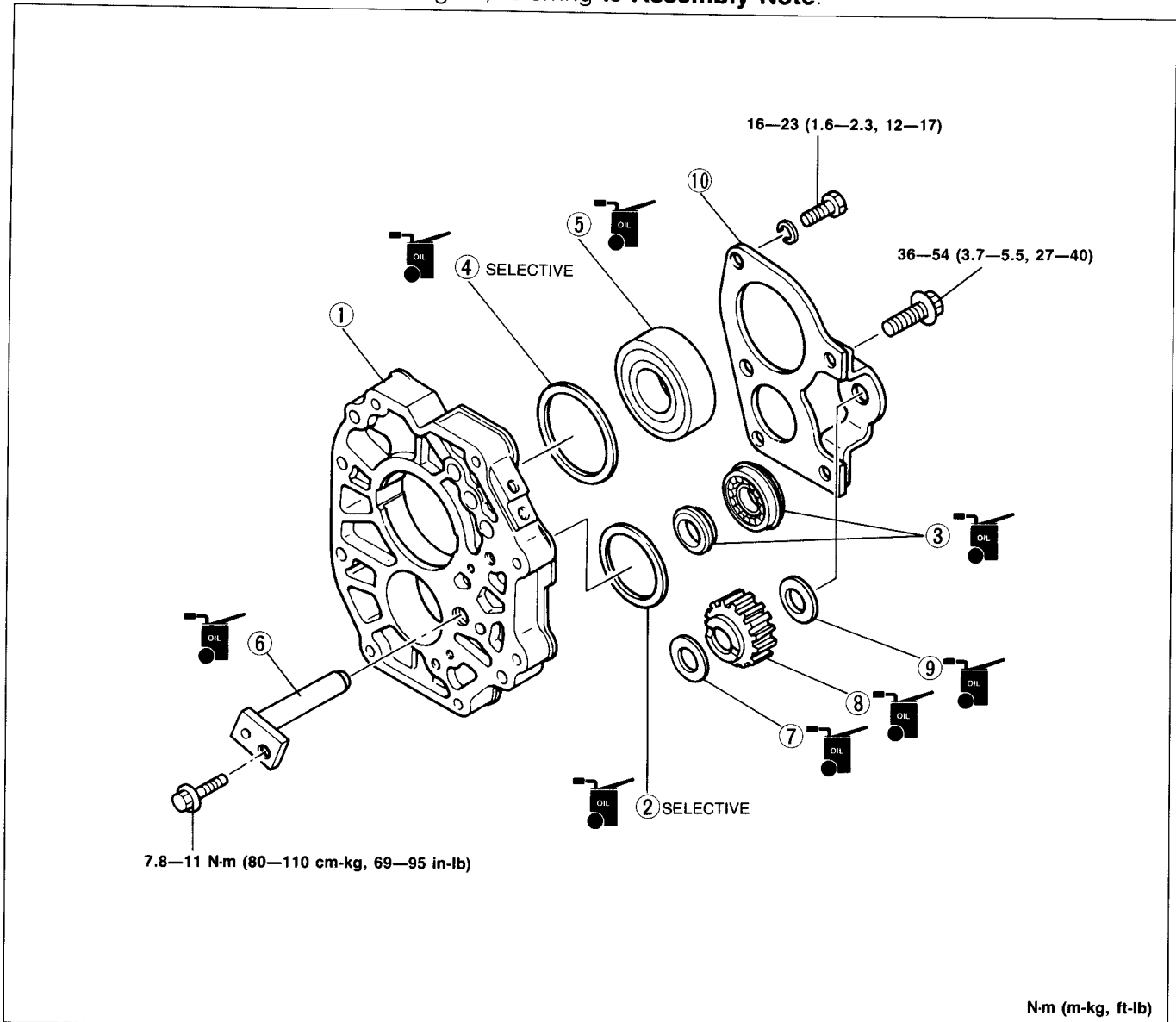

97U0J1-044

- | | | |
|--|---|---|
| 1. Bearing housing | 5. Mainshaft front bearing | 9. Washer |
| 2. Adjustment shim
Installation..... page J1-27 | 6. Reverse idler gear shaft
Installation..... page J1-27 | 10. Bearing cover
Installation..... page J1-27 |
| 3. Countershaft center bearing
Installation..... page J1-26 | 7. Washer | |
| 4. Adjustment shim
Installation..... page J1-27 | 8. Reverse idler gear | |

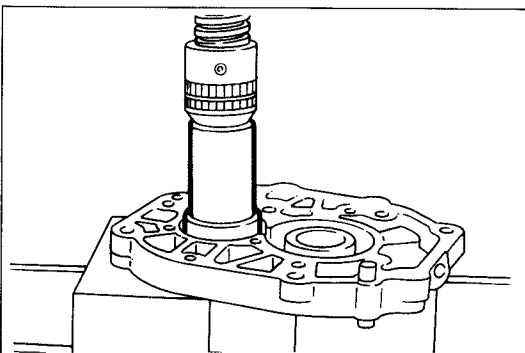

97U0J1-045

Assembly note Countershaft center bearing

1. Press the countershaft center bearing into the bearing housing with a suitable pipe.

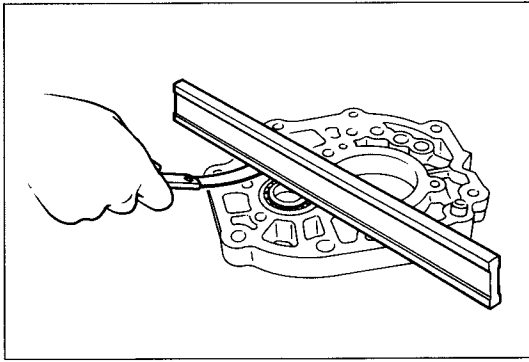

97U0J1-046

2. Measure the clearance between the countershaft center bearing and the bearing housing. If the clearance is not within the standard, adjust it by using an adjustment shim(s).

Standard clearance: 0—0.1mm (0—0.004 in)

Adjustment shim:

0.1mm (0.004 in), 0.3mm (0.012 in)

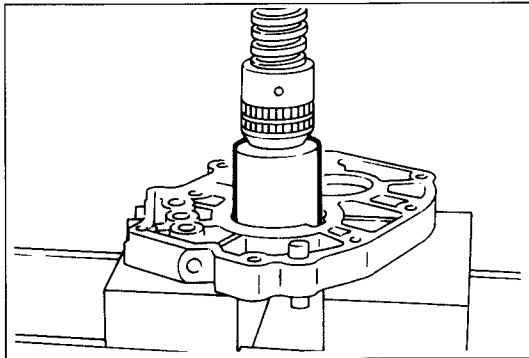

97U0J1-047

Mainshaft front bearing

1. Press the mainshaft front bearing into the bearing housing with a suitable pipe.

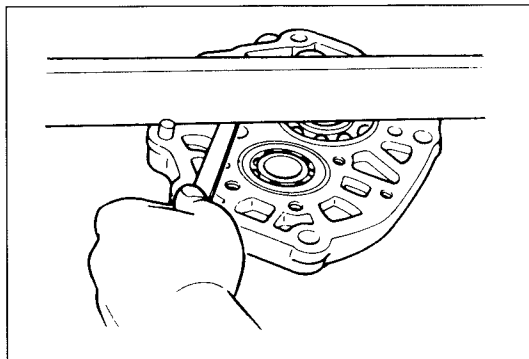

97U0J1-048

2. Measure the clearance between the mainshaft front bearing and the bearing housing. If the clearance is not within the standard, adjust it by using an adjustment shim(s).

Standard clearance: 0—0.1mm (0—0.004 in)

Adjustment shim:

**0.1mm (0.004 in), 0.15mm (0.006 in),
0.3mm (0.012 in)**

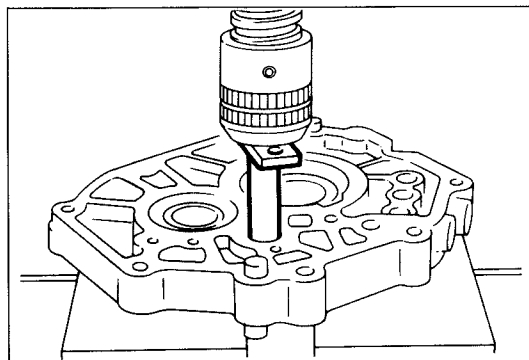

97U0J1-049

Bearing cover

1. Install the reverse idler gear.

Tightening torque:

7.8—11 N·m (80—110 cm·kg, 69—95 in)

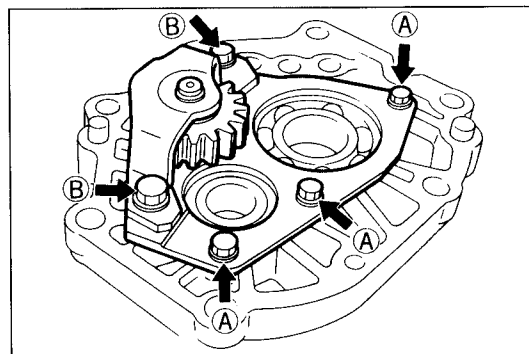

97U0J1-050

2. Install the 2 washers, reverse idler gear, and bearing cover.

Tightening torque:

Ⓐ: 16—23 N·m (1.6—2.3 m·kg, 12—17 ft·lb)

Ⓑ: 36—54 N·m (3.7—5.5 m·kg, 27—40 ft·lb)

J1 TRANSMISSION

Mainshaft Parts

Assemble in the order shown in the figure, referring to **Assembly Note**.

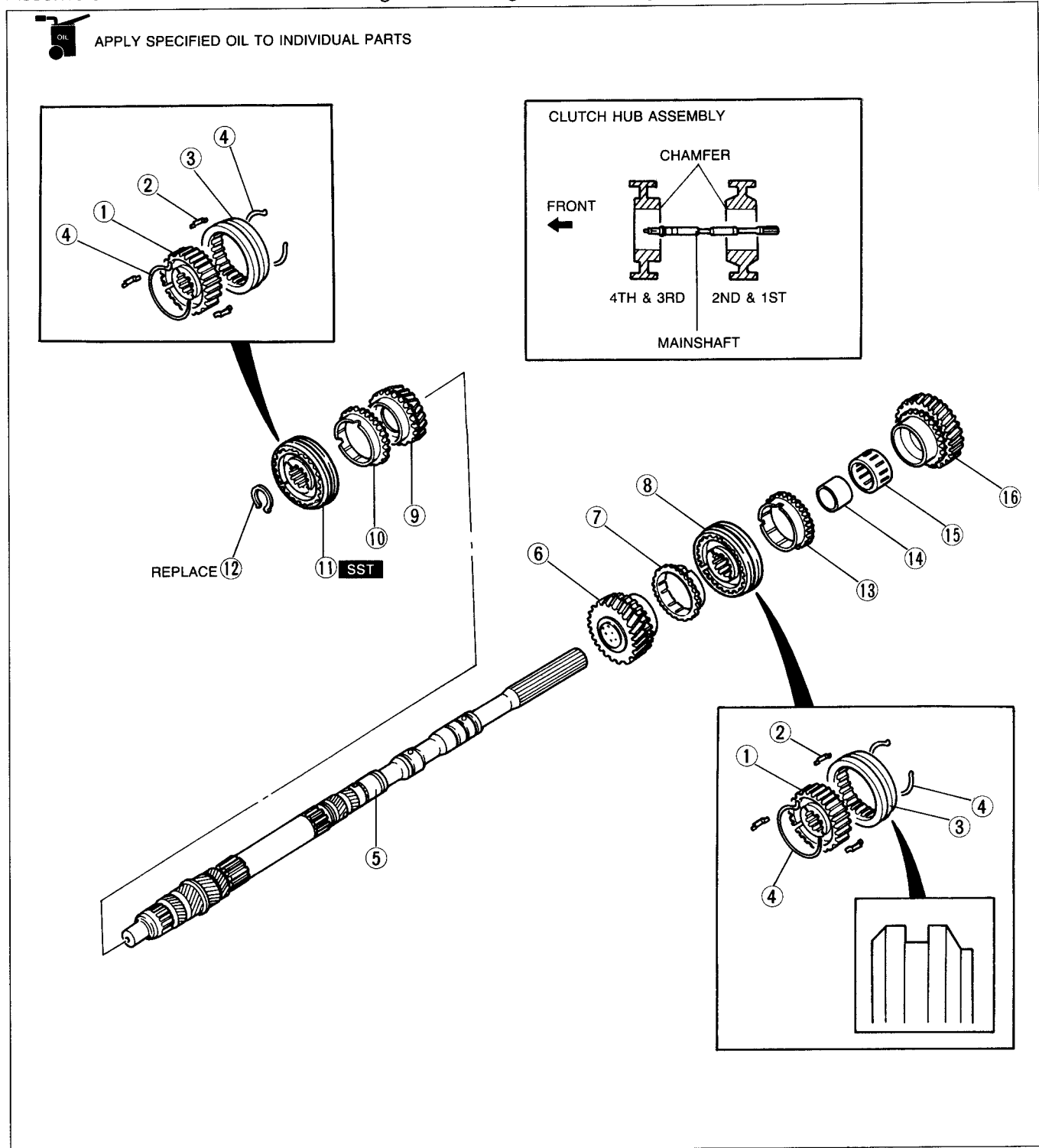

97U0J1-051

- | | | |
|---|--|--|
| 1. Clutch hub | 8. Clutch hub assembly
(1st/2nd)
Installation..... page J1-29 | 12. Snap ring
Installation..... page J1-29 |
| 2. Synchronizer key | 9. 3rd gear
Installation..... page J1-29 | 13. Synchronizer ring |
| 3. Clutch hub sleeve | 10. Synchronizer ring (3rd) | 14. Inner race
Installation..... page J1-29 |
| 4. Synchronizer key spring | 11. Clutch hub assembly
(3rd/4th)
Installation..... page J1-29 | 15. Needle bearing
Installation..... page J1-29 |
| 5. Mainshaft | | 16. 1st gear
Installation..... page J1-29 |
| 6. 2nd gear
Installation..... page J1-29 | | |
| 7. Synchronizer ring | | |

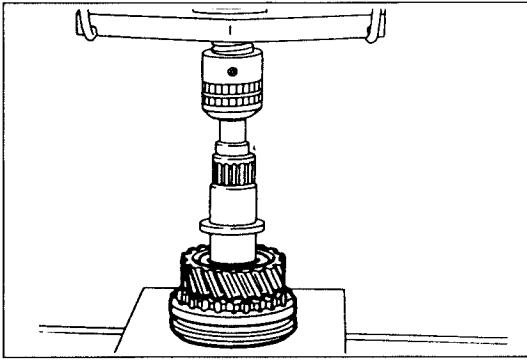

97U0J1-052

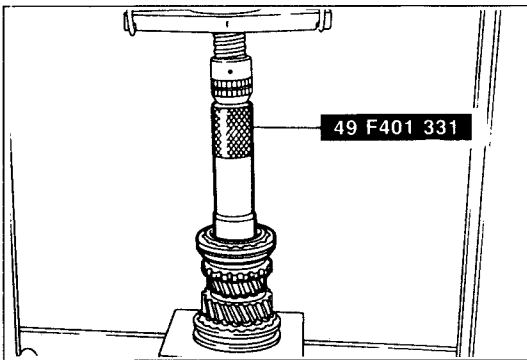

97U0J1-053

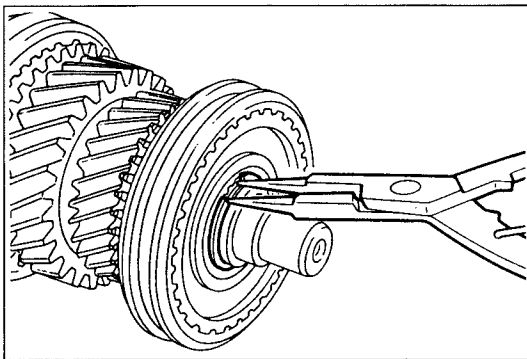

9MU0JX-073

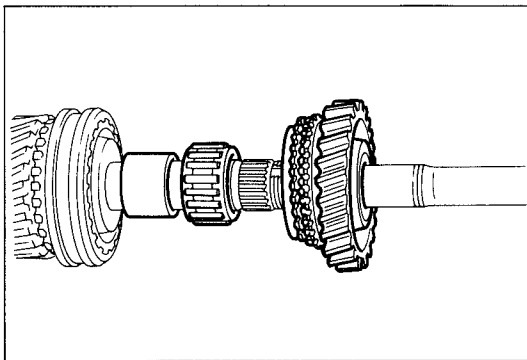

97U0J1-054

Assembly note Clutch hub assembly

1. Set the 2nd gear and the 1st/2nd clutch hub assembly on the mainshaft, then press in the mainshaft.

2. Set the 3rd gear and 3rd/4th clutch hub assembly on the mainshaft, then press on the 3rd/4th clutch hub assembly with the **SST**.

3. Install a new snap ring on the front of the mainshaft.

4. Install the inner race, needle bearing, and 1st gear.

J1 TRANSMISSION

Mainshaft and Countershaft Parts

Assemble in the order shown in the figure, referring to **Assembly Note**.



APPLY SPECIFIED OIL TO INDIVIDUAL PARTS EXCEPT LOCKNUTS

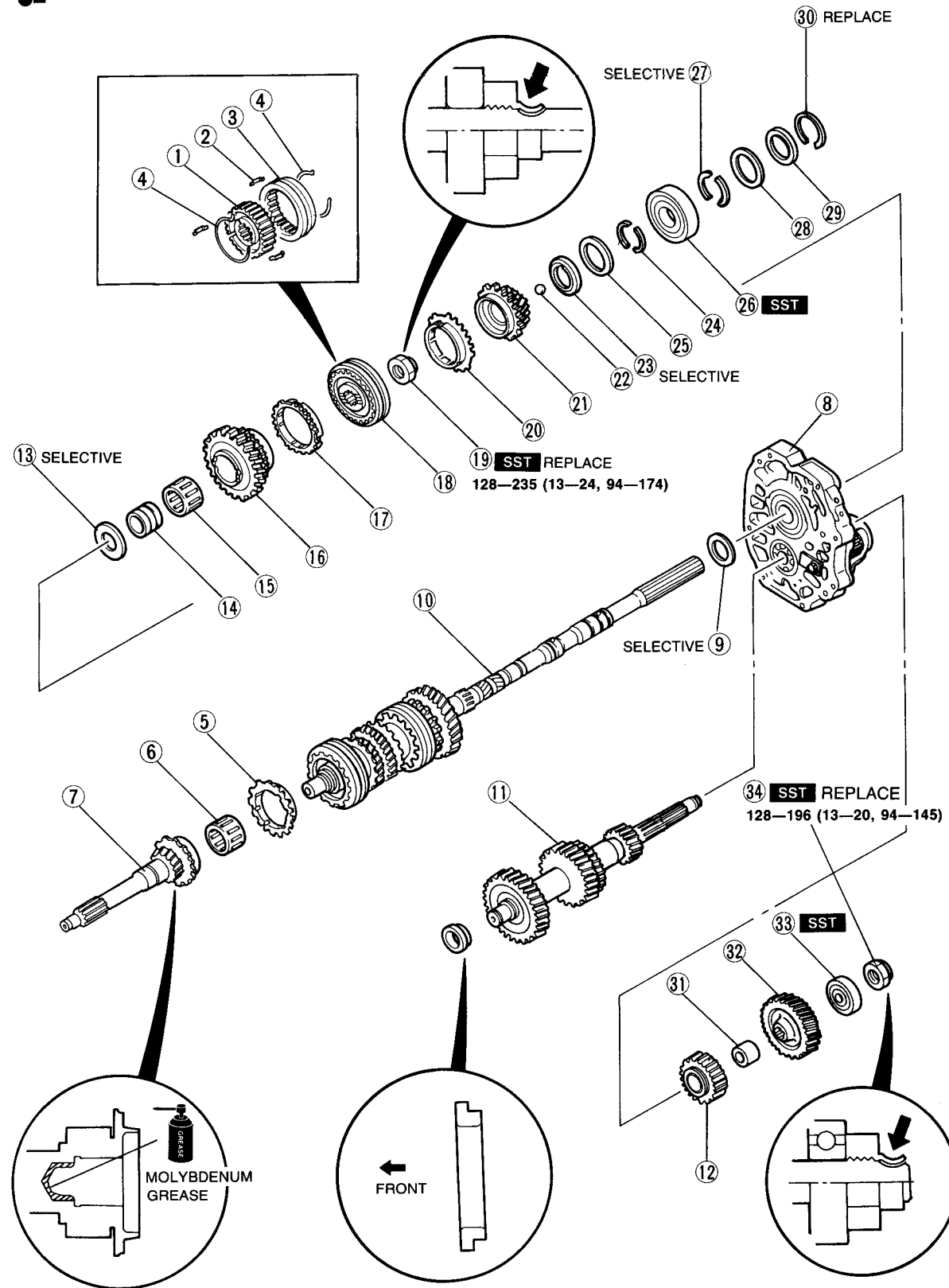

N-m (m-kg, ft-lb)

97U0J1-055

- | | | |
|------------------------------|---------------------------------|-------------------------------|
| 1. Clutch hub | 15. Needle bearing | 26. Mainshaft rear bearing |
| 2. Synchronizer key | 16. Reverse gear | Installation..... page J1-32 |
| 3. Clutch hub sleeve | 17. Synchronizer ring (Reverse) | 27. C-washer |
| 4. Synchronizer key spring | 18. Clutch hub assembly | Installation..... page J1-32 |
| 5. Synchronizer ring (4th) | 19. Locknut (Mainshaft) | 28. Retaining ring |
| 6. Needle bearing | Installation..... page J1-31 | Installation..... page J1-32 |
| 7. Main drive gear | 20. Synchronizer ring (5th) | 29. Washer |
| 8. Bearing housing assembly | 21. 5th gear | Installation..... page J1-32 |
| 9. Washer | 22. Steel ball | 30. Snap ring |
| 10. Mainshaft gear assembly | Installation..... page J1-32 | Installation..... page J1-32 |
| Installation..... page J1-31 | 23. Thrust lock washer | 31. Spacer |
| 11. Countershaft | Installation..... page J1-32 | 32. Counter 5th gear |
| Installation..... page J1-31 | 24. C-washer | 33. Countershaft rear bearing |
| 12. Counter reverse gear | Installation..... page J1-32 | Installation..... page J1-32 |
| 13. Washer | 25. Retaining ring | 34. Locknut (Countershaft) |
| 14. Inner race | Installation..... page J1-32 | Installation..... page J1-33 |

97U0J1-056

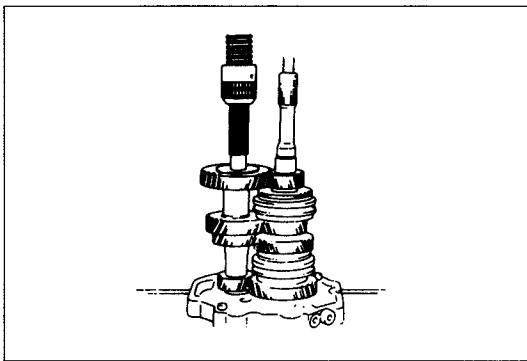

97U0J1-057

Assembly note Mainshaft and countershaft

1. Place the mainshaft gear assembly and the countershaft on the bearing housing.
2. Use a suitable bar to press in the countershaft.

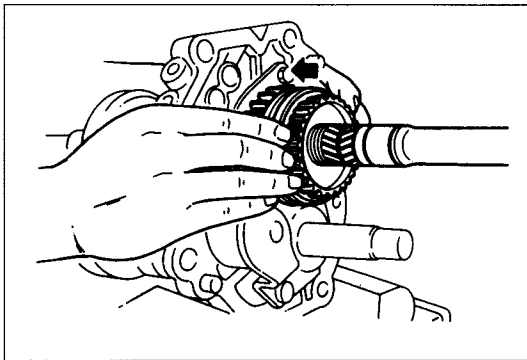

97U0J1-058

Locknut (Mainshaft)

Note

Use pads in the vise to prevent damaging the bearing housing.

1. Secure the bearing housing in a vise.
2. Slide the clutch hub sleeves onto 1st and reverse gears to lock the mainshaft.

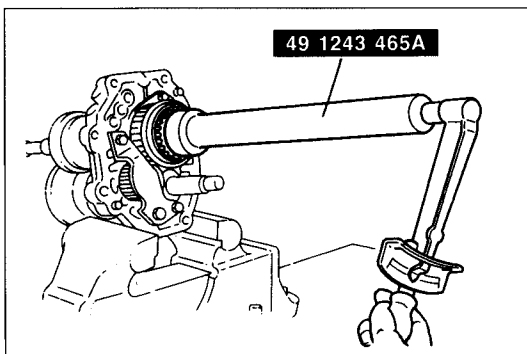

97U0J1-059

3. Tighten a new locknut with the **SST**.

Tightening torque:

128—235 N·m (13—24 m·kg, 94—174 ft·lb)

4. Use a chisel to crimp the locknut.

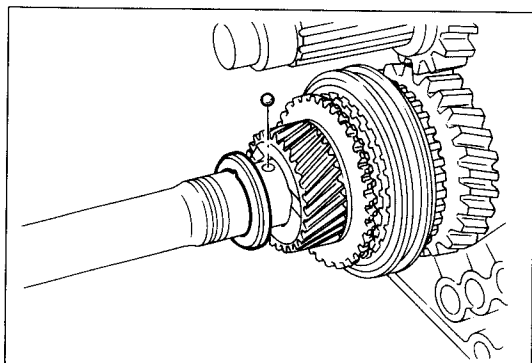

97U0J1-060

Thrust lock washer

1. Insert the steel ball and the thrust lock washer for 5th gear.

Caution

- a) Use only 3.0mm (0.118 in) C-washers, otherwise; it may not be possible to install the rear C-washers.
- b) The two C-washers must be the same thickness, or bearing failure will result.

2. Install the C-washers and hold them with the retaining ring.

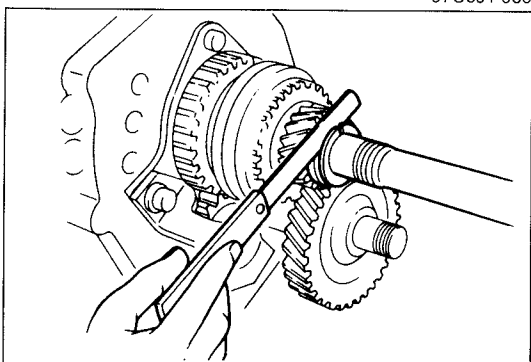

97U0J1-061

3. Measure the clearance between the thrust lock washer and C-washers (5th gear end play).

If the end play is not within the standard, adjust it by selecting a thrust lock washer.

Standard play: 0.1—0.3mm (0.004— 0.012 in)

Thrust lock washer thickness:

**6.2mm (0.244 in), 6.4mm (0.252 in),
6.5mm (0.256 in), 6.6mm (0.260 in)**

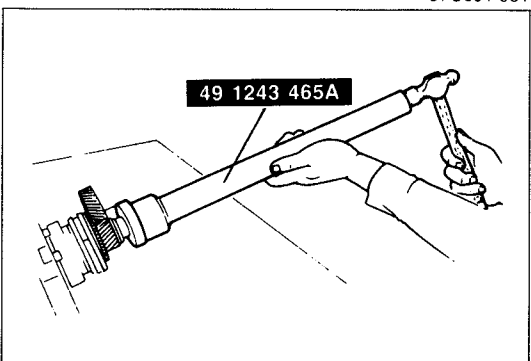

97U0J1-062

Mainshaft rear bearing

1. Drive on the mainshaft rear bearing with the **SST**. Install the C-washers, retaining ring and washer, and secure them with a new snap ring.

2. Measure the clearance between the C-washers and washer. If end play is not within the standard, adjust it by selecting the proper C-washers.

Standard play: 0—0.1mm (0—0.004 in)

C-washer thickness:

**2.9mm (0.114 in), 3.0mm (0.118 in),
3.1mm (0.122 in), 3.2mm (0.126 in)**

Caution

Check to be sure there is no clearance between the mainshaft rear bearing and the C-washers.

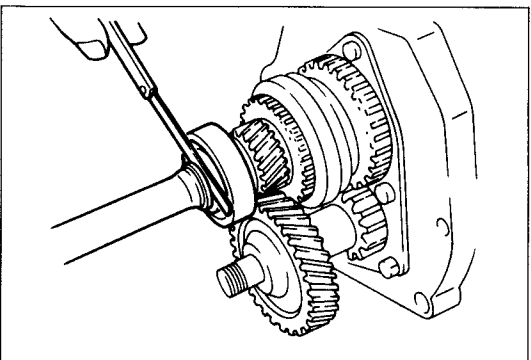

97U0J1-063

Countershaft rear bearing

Drive the countershaft rear bearing onto the countershaft with the **SST**.

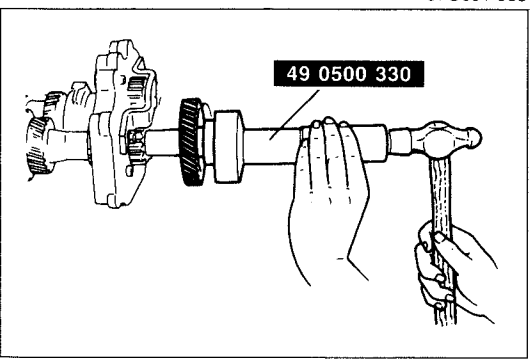

97U0J1-064

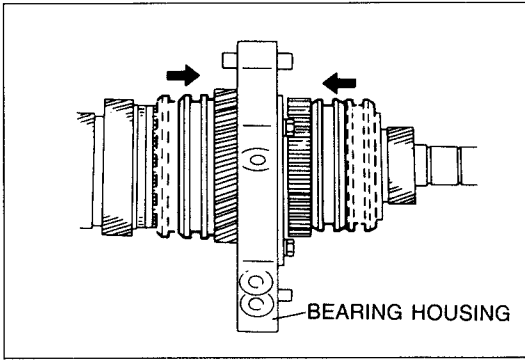

97U0J1-065

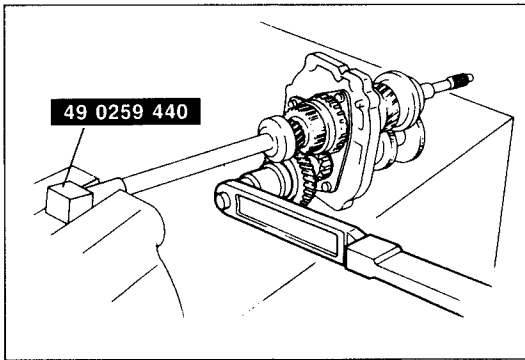

97U0J1-066

Locknut (Countershaft)

1. Shift the clutch hub sleeves to 1st gear and reverse gear to put the gears in a double-engaged condition.

Note

Use pads in the vise to prevent damaging the SST.

2. Connect the **SST** to the mainshaft and tighten it securely in a vise.
3. Tighten the new locknut.

Tightening torque:

128—196 N·m (13—20 m·kg, 94—145 ft·lb)

4. Use a chisel to crimp the locknut.

J1 TRANSMISSION

Shift Fork and Shift Rod Parts

Assemble in the order shown in the figure, referring to **Assembly Note**.

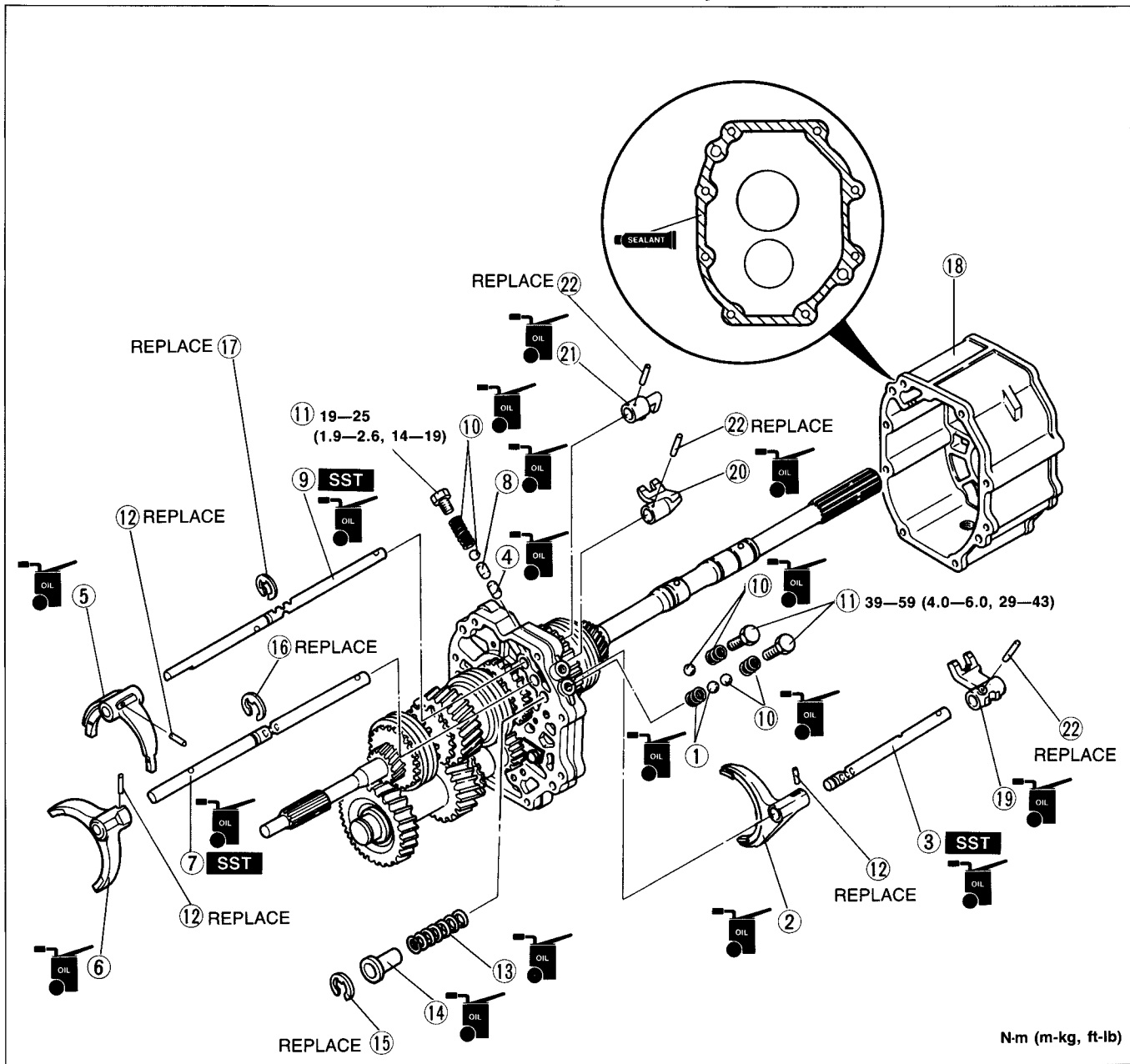

97U0J1-067

- | | | |
|---|--|---|
| 1. Spring and ball
Installation..... page J1-35 | 9. 1st/2nd shift rod
Installation..... page J1-36 | 16. Clip
Installation..... page J1-36 |
| 2. 5th/Reverse shift fork
Installation..... page J1-35 | 10. Ball and spring
Installation..... page J1-36 | 17. Clip
Installation..... page J1-36 |
| 3. 5th/Reverse shift rod
Installation..... page J1-35 | 11. Cap plug
Installation..... page J1-36 | 18. Intermediate housing
Installation..... page J1-37 |
| 4. Interlock pin
Installation..... page J1-35 | 12. Roll pin
Installation..... page J1-36 | 19. 5th/Reverse shift rod end
Installation..... page J1-37 |
| 5. 1st/2nd shift fork
Installation..... page J1-36 | 13. Spring
Installation..... page J1-36 | 20. 3rd/4th shift rod end
Installation..... page J1-37 |
| 6. 3rd/4th shift fork
Installation..... page J1-36 | 14. Spacer
Installation..... page J1-36 | 21. 1st/2nd shift rod end
Installation..... page J1-37 |
| 7. 3rd/4th shift rod
Installation..... page J1-36 | 15. Clip
Installation..... page J1-36 | 22. Roll pin
Installation..... page J1-37 |
| 8. Interlock pin
Installation..... page J1-36 | | |

Shift fork and rod

Note

There are 2 types of springs; be sure to install them correctly.

1. Insert the spring and ball (5th/Reverse) into the bearing housing.

2. Press the spring and ball (5th/Reverse) with a standard screwdriver and the **SST** to install the shift rod.

3. Install the 5th/Reverse shift fork and 5th/Reverse shift rod into the bearing housing.

4. Position the interlock pin into the bearing housing with the **SST**.

5. Check to be sure that the interlock pin is correctly installed.

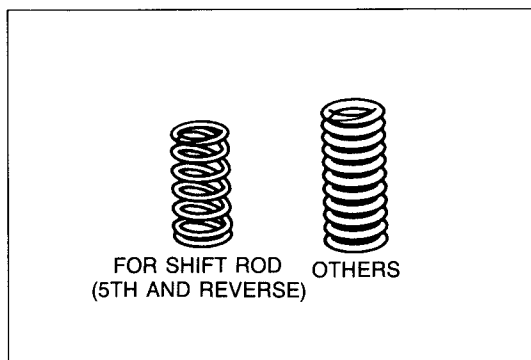

97U0J1-068

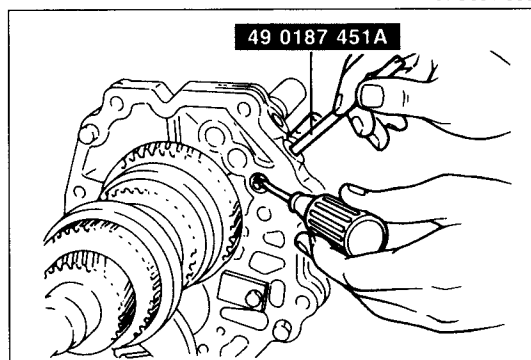

97U0J1-069

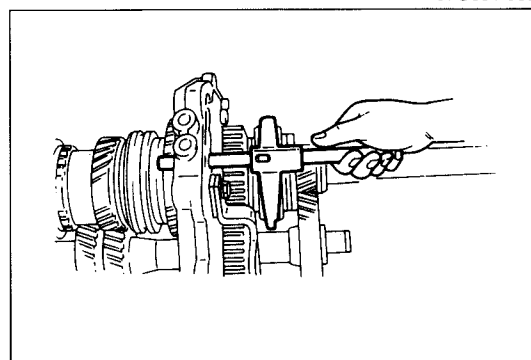

97U0J1-070

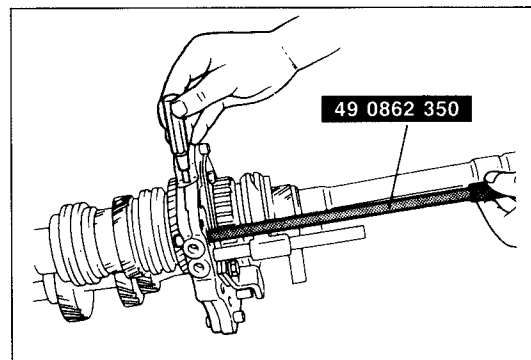

97U0J1-071

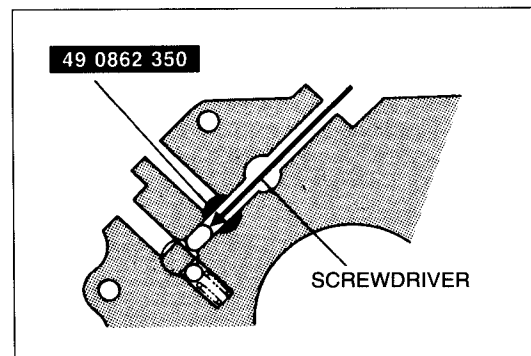

97U0J1-072

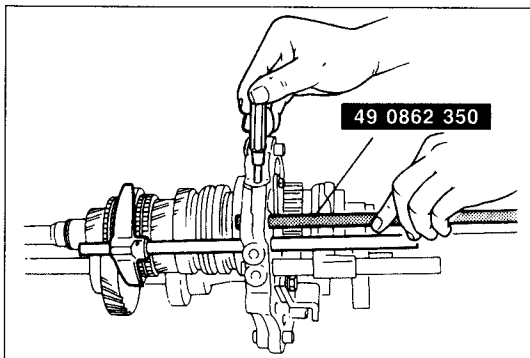

97U0J1-073

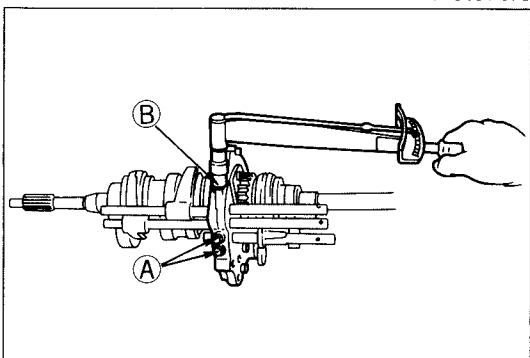

97U0J1-074

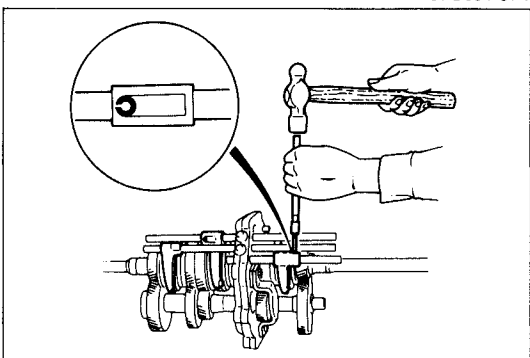

97U0J1-075

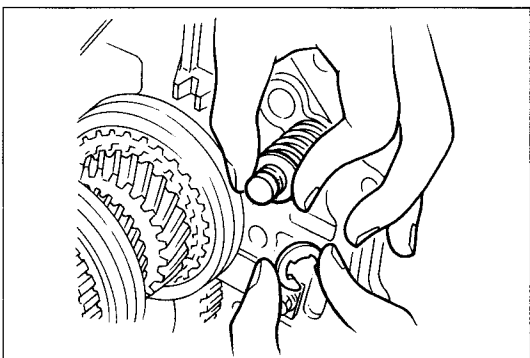

97U0J1-076

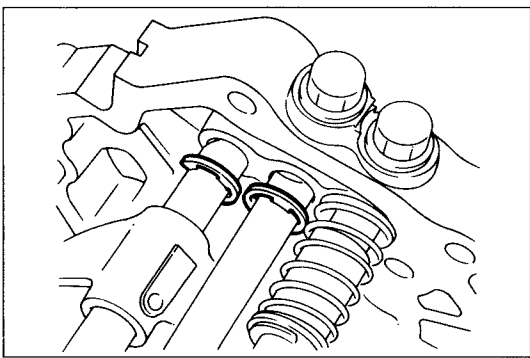

97U0J1-077

6. Set the 1st/2nd shift fork onto the 1st/2nd clutch hub assembly.
7. Install the 3rd/4th shift fork and 3rd/4th shift rod, and install the interlock pin into the bearing housing as in Step 4.

8. Install the 1st/2nd shift fork and 1st/2nd shift rod.
9. Install the balls, springs, and cap plugs.

Tightening torque:

- A: 39—59 N·m (4.0—6.0 m·kg, 29—43 ft·lb)
- B: 19—25 N·m (1.9—2.6 m·kg, 14—19 ft·lb)

Caution

The roll pin should be installed so that the seam of the pin faces as shown in the figure.

10. Install new roll pins into each shift fork.
11. Slide the spring and spacer onto the 5th/Reverse shift rod. While pressing the spacer, install a new clip.
12. Install new clips to the 3rd/4th shift rod and 1st/2nd shift rod.

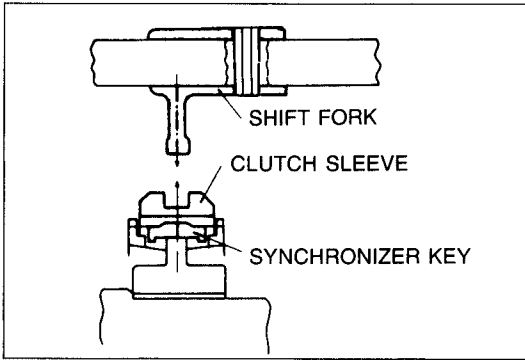

97U0J1-078

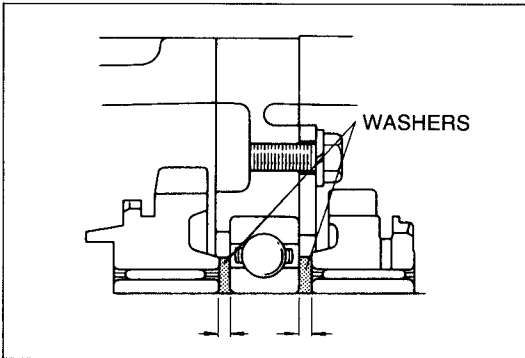

97U0J1-079

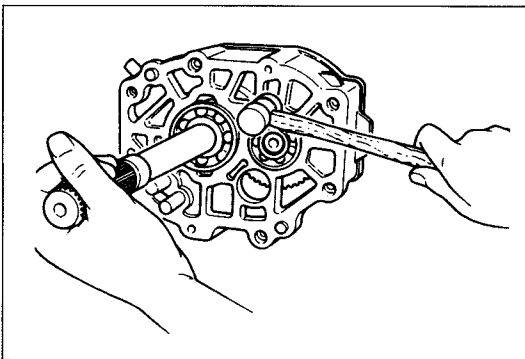

97U0J1-080

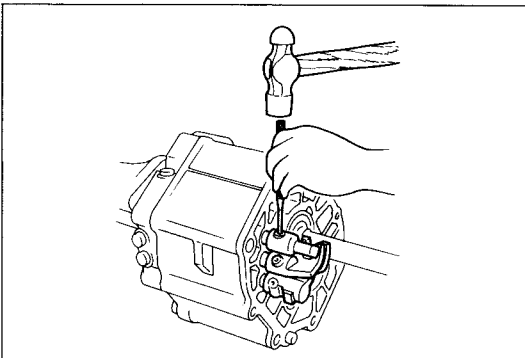

97U0J1-081

13. Check to be sure that the centers of the shift fork and clutch hub sleeve are aligned properly. If they are not, select the proper washer for between 1st gear and the mainshaft front bearing, and between reverse gear and the mainshaft front bearing.

14. The following washer thicknesses are available.

2.2mm (0.0866 in)	3.2mm (0.1260 in)
2.7mm (0.1063 in)	3.7mm (0.1457 in)
3.0mm (0.1181 in)	

Caution

The total thicknesses of the front and rear washers should be 5.9mm (0.2323 in) or 6.0mm (0.2362 in).

Intermediate housing

1. Apply sealant to the contacting surfaces of the intermediate housing and bearing housing.
2. Mount the intermediate housing to the bearing housing by tapping it lightly with a plastic hammer.

Shift rod end

Caution

The roll pin should be installed so that the seam of the pin faces forward.

Install the shift rod ends onto the proper shift rods and secure them with new roll pins.

J1 TRANSMISSION

Housing Components

Assemble in the order shown in the figure, referring to **Assembly Note**.

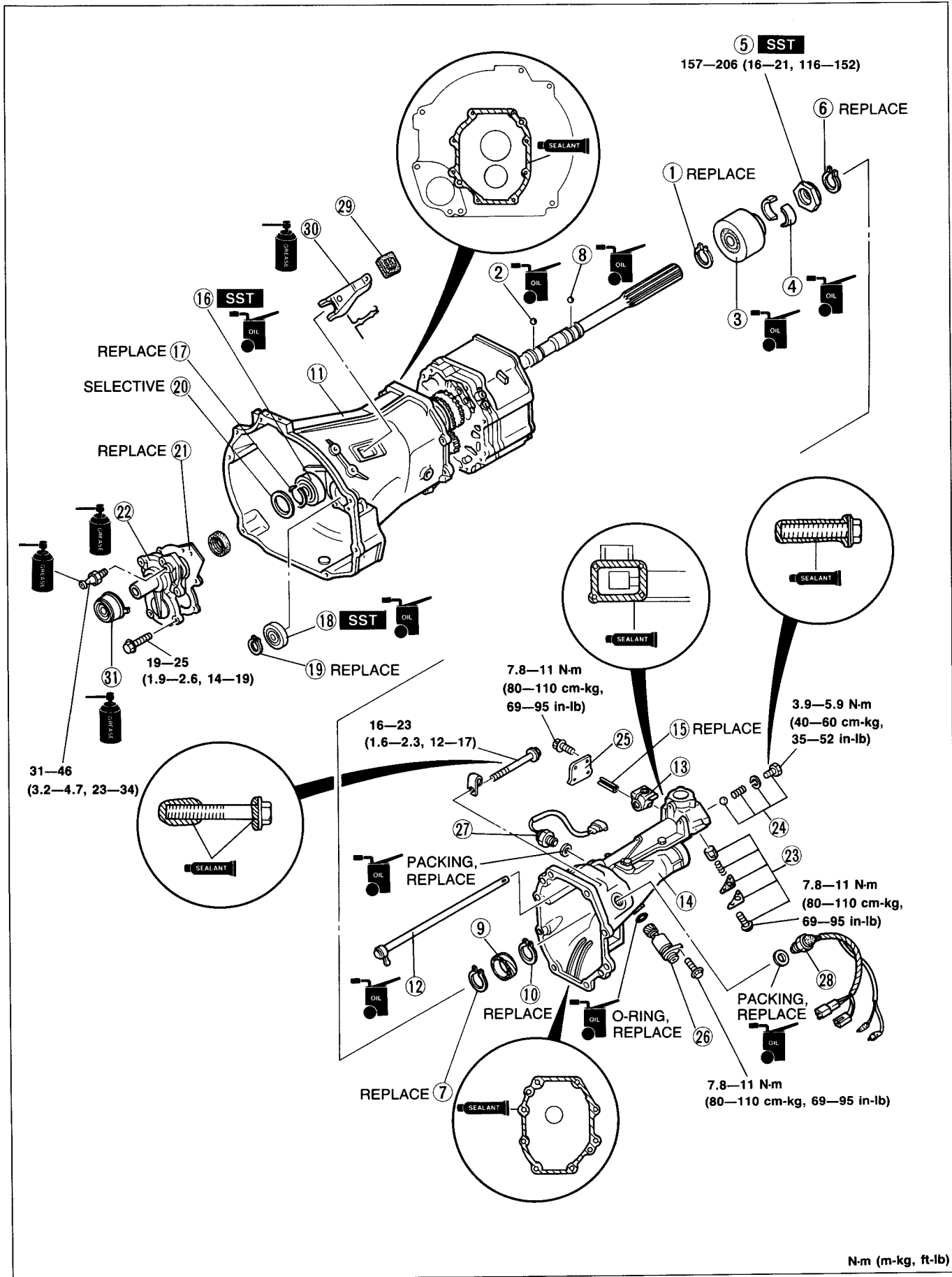

N-m (m-kg, ft-lb)

97U0J1-082

- | | | |
|---|--|--|
| 1. Snap ring
Installation..... page J1-39 | 13. Control lever end
Installation..... page J1-40 | 23. Select-lock spindle, spring,
and spring cap
Installation..... page J1-41 |
| 2. Steel ball
Installation..... page J1-39 | 14. Extension housing
Installation..... page J1-40 | 24. Steel ball, spring, and spring
cap
Installation..... page J1-41 |
| 3. Dynamic damper
Installation..... page J1-39 | 15. Roll pin
Installation..... page J1-40 | 25. Blind cover
Installation..... page J1-41 |
| 4. Taper cotter
Installation..... page J1-39 | 16. Main drive gear bearing
Installation..... page J1-40 | 26. Speedometer drive gear |
| 5. Locknut
Installation..... page J1-39 | 17. Snap ring
Installation..... page J1-40 | 27. Neutral switch |
| 6. Snap ring
Installation..... page J1-39 | 18. Countershaft front bearing
Installation..... page J1-40 | 28. Back-up light and 5th switch |
| 7. Snap ring | 19. Snap ring
Installation..... page J1-40 | 29. Boot |
| 8. Steel ball | 20. Adjustment shim
Installation..... page J1-41 | 30. Release fork
Installation..... page J1-42 |
| 9. Speedometer driven gear | 21. Gasket
Installation..... page J1-41 | 31. Release bearing
Installation..... page J1-42 |
| 10. Snap ring | 22. Front cover
Installation..... page J1-41 | |
| 11. Transmission case
Installation..... page J1-40 | | |
| 12. Control lever
Installation..... page J1-40 | | |

97U0J1-083

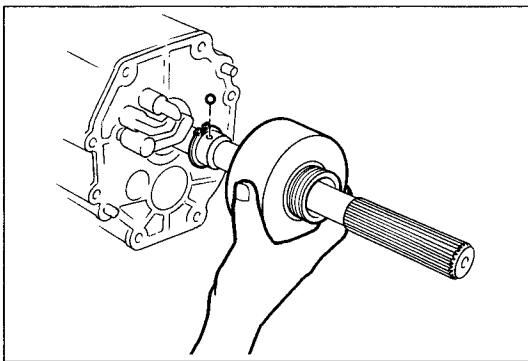

97U0J1-084

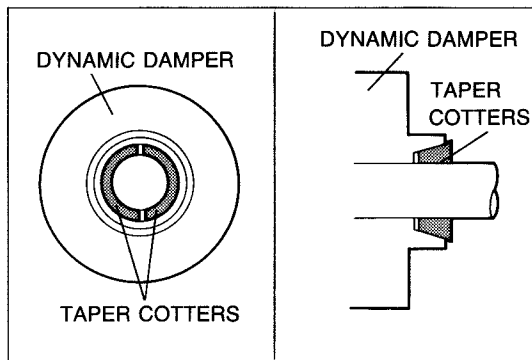

97U0J1-085

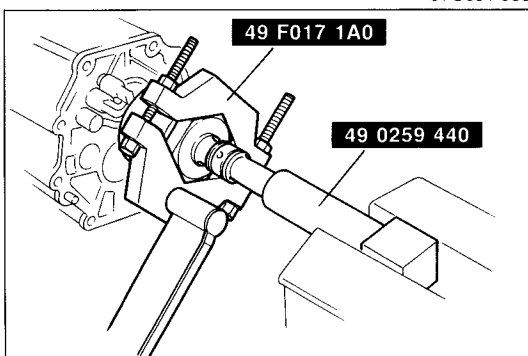

97U0J1-086

Assembly note

Locknut

1. Install a new snap ring, the steel ball, and the dynamic damper.

2. Set the taper cotters between the mainshaft and dynamic damper.

Note

Use pads in the vise to prevent damaging the SST.

3. Connect the **SST** to the mainshaft and tighten it securely in a vise.
4. Install the locknut with the **SST**.

Tightening torque (without SST):

157—206 N·m (16—21 m·kg, 116—152 ft·lb)

Tightening torque (with SST):

Torque wrench length (in)	Tightening torque with SST (N-m, m-kg, ft-lb)
18 1/2	141—184, 15—19, 104—136
18 11/16	141—185, 15—19, 104—137
18 3/4	141—185, 15—19, 104—137
20 5/8	142—186, 15—19, 105—137
21 1/2	143—187, 15—19, 106—138
22	143—188, 15—19, 106—139
23	144—188, 15—19, 106—139
23 3/4	144—189, 15—19, 106—139

5. Install a new snap ring to secure the locknut.

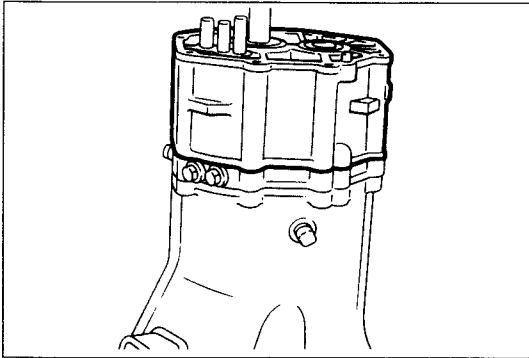

97U0J1-087

Transmission case

1. Apply sealant to the contact surfaces of the bearing housing and transmission case.
2. Mount the transmission case to the bearing housing.

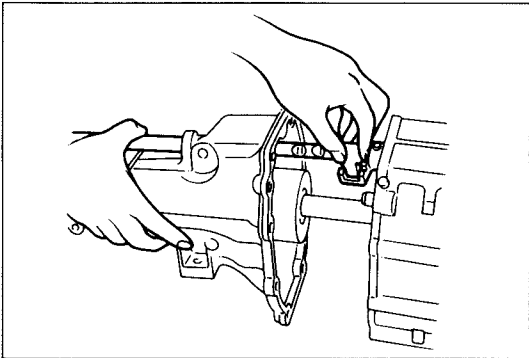

97U0J1-088

Extension housing

1. Apply sealant to the contact surfaces of the intermediate housing and extension housing.
2. Set the control lever to the shift rod end groove.
3. Set the control lever end into the extension housing, and install the extension housing.
4. Apply sealant to the bolt threads, then install the bolts.

Tightening torque:

16—23 N-m (1.6—2.3 m-kg, 12—17 ft-lb)

Caution

The roll pin should be installed so that the seam of the pin face as shown in the figure.

5. Install a new roll pin into the control lever end.

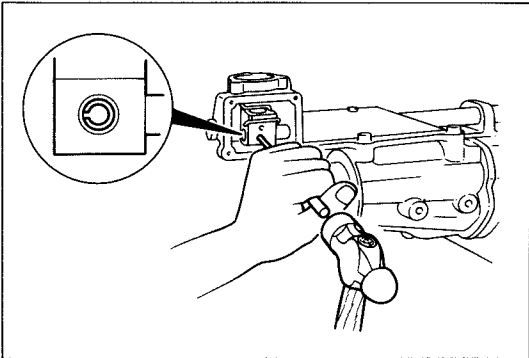

97U0J1-089

Main drive gear bearing

Drive on the main drive gear bearing with the **SST**, and secure it with a new snap ring.

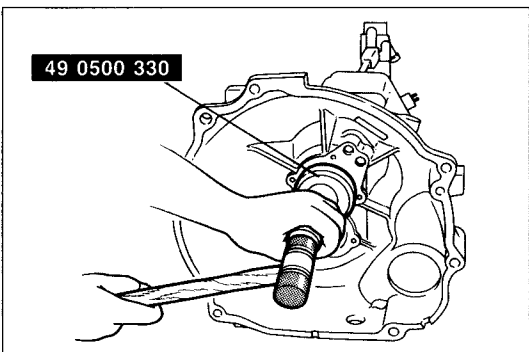

97U0J1-090

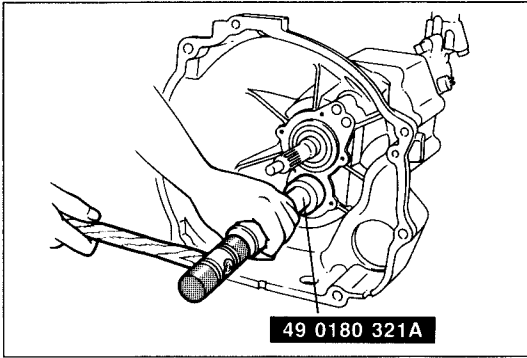

97U0J1-091

Countershaft front bearing

Drive on the countershaft front bearing with the **SST**, and secure it with a new snap ring.

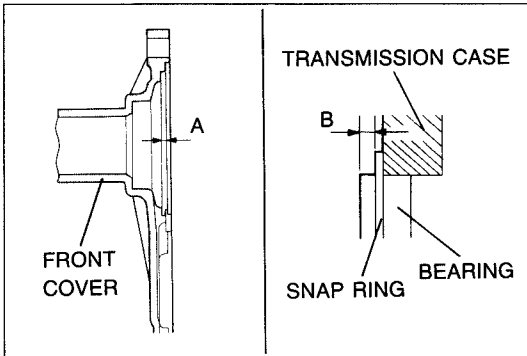

97U0J1-092

Front cover

1. After measuring dimensions (A) and (B) shown in the figure, use an adjustment shim(s), as specified below, of the thickness corresponding to the value of (A) minus (B), so that bearing end play will be within the standard value.

Bearing end play: 0—0.1mm (0—0.004 in)

Adjustment shim thickness:

**0.10mm (0.004 in), 0.15mm (0.006 in),
0.30mm (0.012 in)**

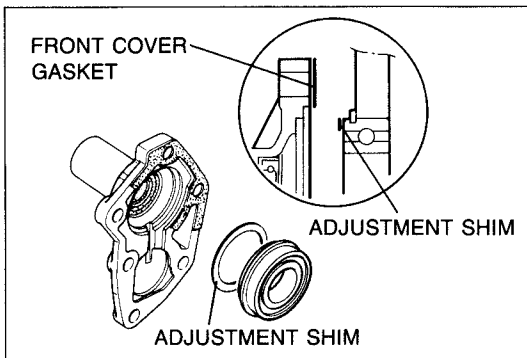

97U0J1-093

2. Install the new gasket and front cover.

Tightening torque:

19—25 N·m (1.9—2.6 m·kg, 14—19 ft·lb)

Select-lock spindle

1. Install the select-lock spindle, spring, and spring cap.

Tightening torque:

7.8—11 N·m (80—110 cm·kg, 69—95 in·lb)

2. Apply sealant to the spring cap threads.

Note

If the select-lock spindle is not pushed down, the ball will not correctly engage it.

3. Push the select-lock spindle down by pushing on the control rod.

4. Insert the ball and spring, and install the spring cap.

Tightening torque:

3.9—5.9 N·m (40—60 cm·kg, 35—52 in·lb)

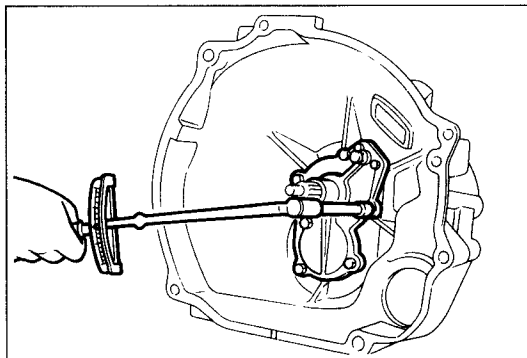

97U0J1-094

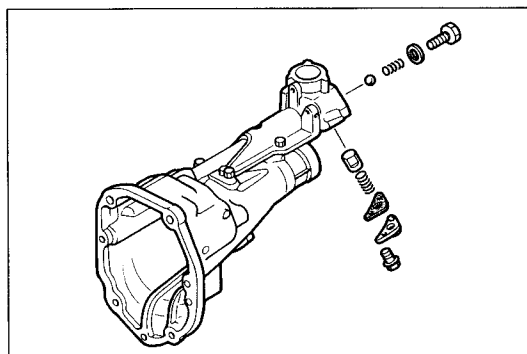

97U0J1-095

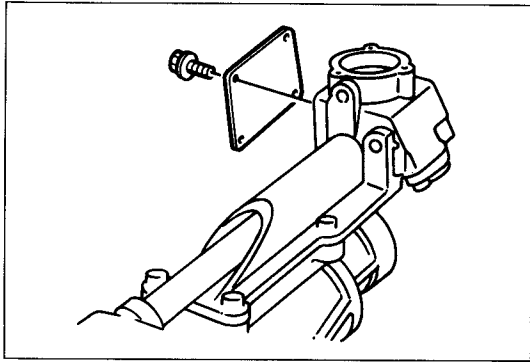

97U0J1-095

5. Apply sealant to the contact surfaces of the change control case and blind cover.
6. Install the blind cover.

Tightening torque:

7.8—11 N·m (80—110 cm·kg, 69—95 in·lb)

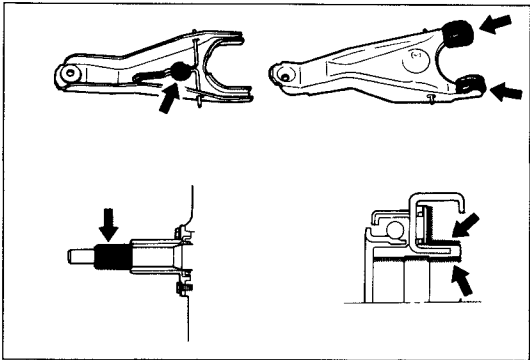

9MU0JX-110

Release fork

1. Apply Mori white TA No.2 or equivalent organic molybdenum grease to the shaded areas of the release bearing and release fork.
2. Install the release bearing and release fork.

INSTALLATION

1. Install in the reverse order of removal, referring to **Installation Note**.
2. After installation, fill the transmission with the specified oil.

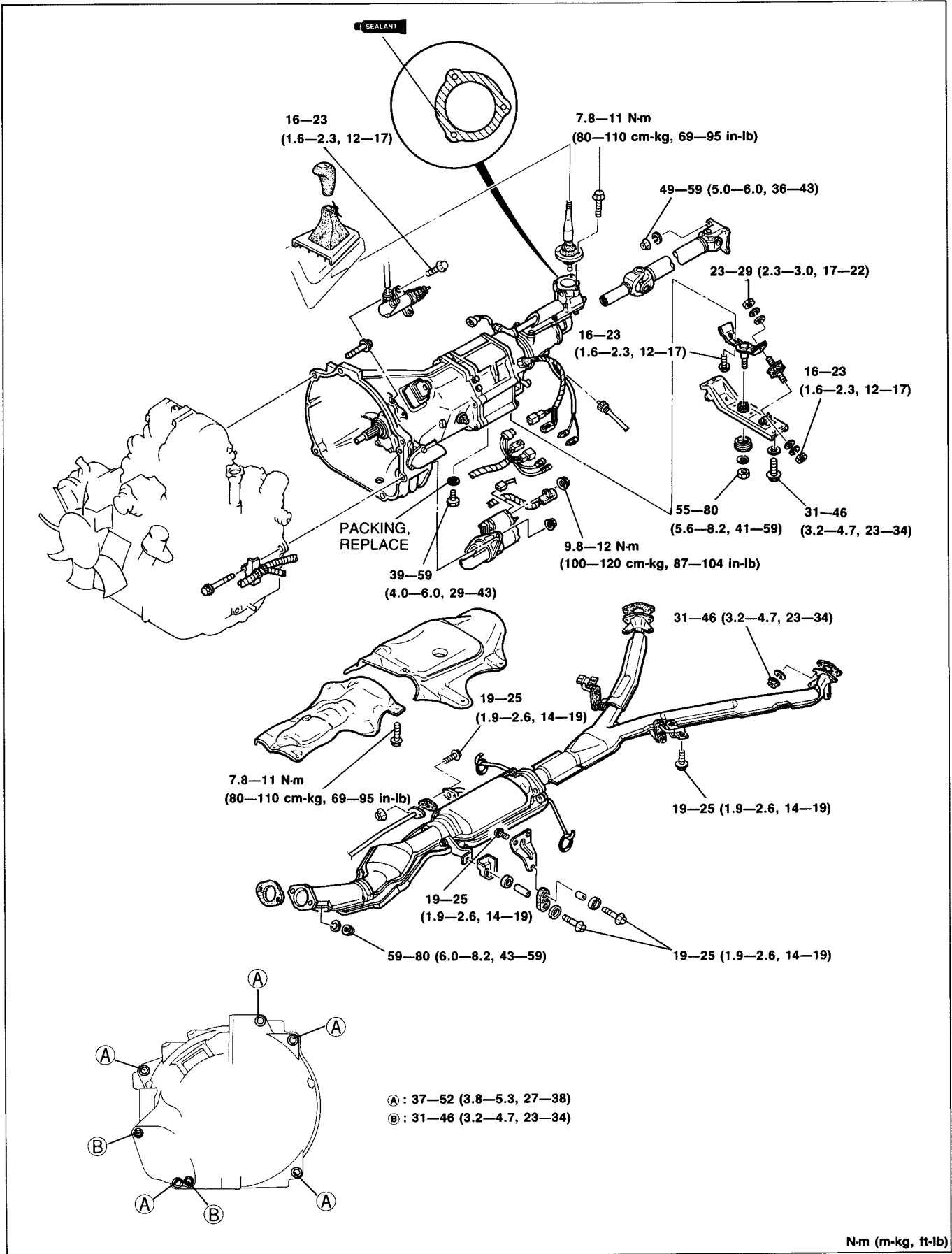

N-m (m-kg, ft-lb)

97U0J1-096

J1-43

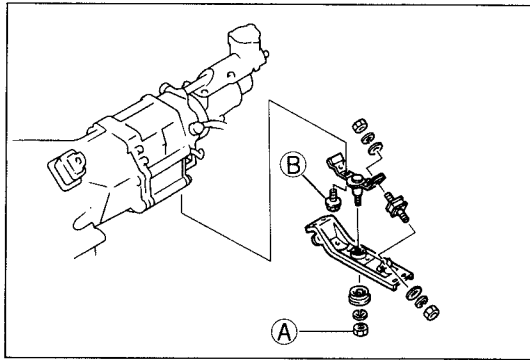

97U0J1-097

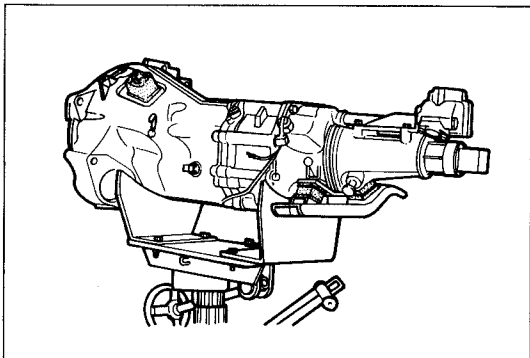

9MU0JX-112

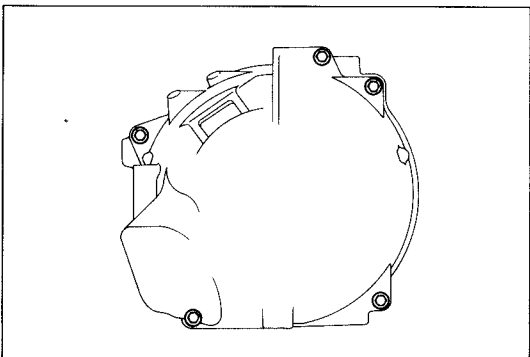

97U0J1-098

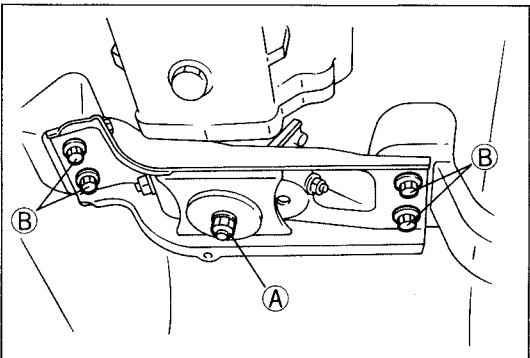

97U0J1-099

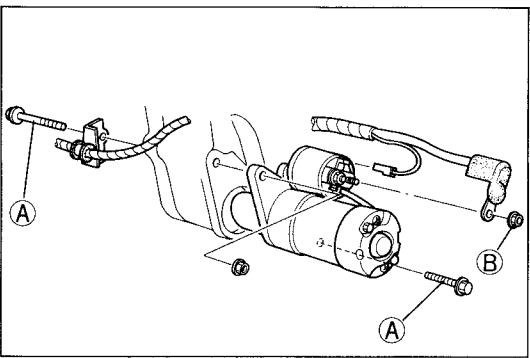

97U0J1-100

Installation Note

1. Install the transmission mount rubber on the transmission.

Tightening torque:

Ⓑ: 16—23 N·m (1.6—2.3 m·kg, 12—17 ft·lb)

2. Loosely tighten nut Ⓐ.

3. Set the transmission on a transmission jack.

4. Raise the transmission into place and install and tighten the installation bolts.

Tightening torque:

37—52 N·m (3.8—5.3 m·kg, 27—38 ft·lb)

5. Tighten bolts Ⓑ.

Tightening torque:

Ⓑ: 31—46 N·m (3.2—4.7 m·kg, 23—34 ft·lb)

6. Tighten nut Ⓐ.

Tightening torque:

Ⓐ: 55—80 N·m (5.6—8.2 m·kg, 41—59 ft·lb)

7. Install and tighten the starter to the specified torque.

Tightening torque:

Ⓐ: 31—46 N·m (3.2—4.7 m·kg, 23—34 ft·lb)

Ⓑ: 9.8—12 N·m (100—120 cm·kg, 87—104 in·lb)

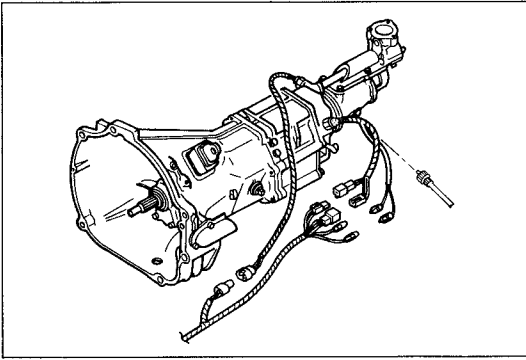

97U0J1-101

8. Connect the neutral switch, and back-up light and 5th switch connectors.
9. Install the speedometer cable.

Note

Align the matching marks and install the propeller shaft.

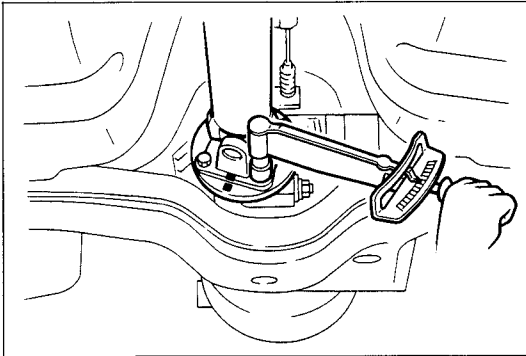

97U0J1-102

10. Install the propeller shaft. (Refer to Section L)

Tightening torque:

49—59 N·m (5.0—6.0 m·kg, 36—43 ft·lb)

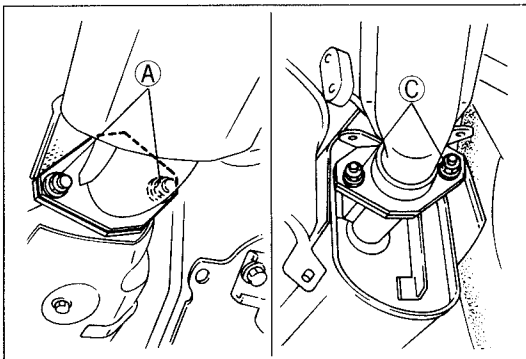

97U0J1-103

11. Install the heat insulator and exhaust pipes.

Tightening torque:

Heat insulator:

7.8—11 N·m (80—110 cm·kg, 69—95 in·lb)

Exhaust pipes:

(A): 59—80 N·m (6.0—8.2 m·kg, 43—59 ft·lb)

(B): 19—25 N·m (1.9—2.6 m·kg, 14—19 ft·lb)

(C): 31—46 N·m (3.2—4.7 m·kg, 23—34 ft·lb)

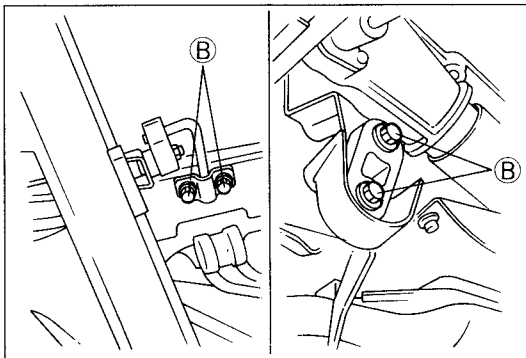

97U0J1-104

12. Install the clutch release cylinder.

Tightening torque:

16—23 N·m (1.6—2.3 m·kg, 12—17 ft·lb)

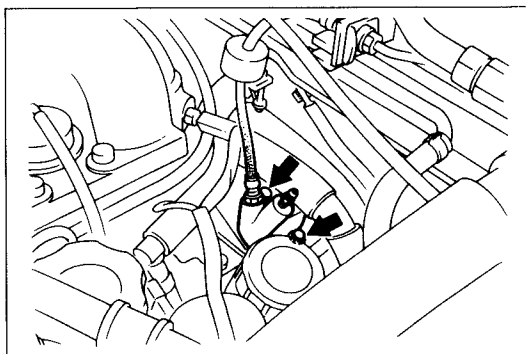

97U0J1-104

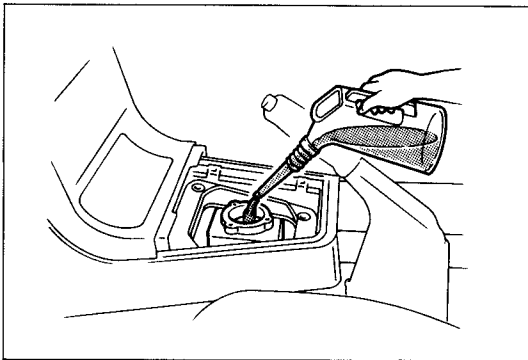

97U0J1-105

13. Pour the specified amount of oil into the change control case.

Note

Add the specified oil whenever the extension housing has been removed.

Specified oil

Grade: API service GL-4 or GL-5

All season: SAE 75W-90

Above 10°C (50°F): SAE 80W-90

Specified amount: 80—95 cc (4.9—5.8 cu-in)

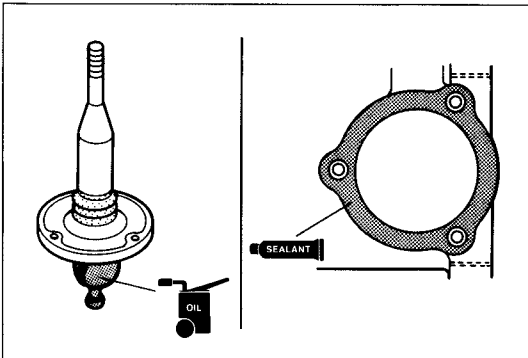

97U0J1-106

14. Apply oil to the shift lever as shown.

15. Apply sealant to the contact surfaces of the boot panel and change control case.

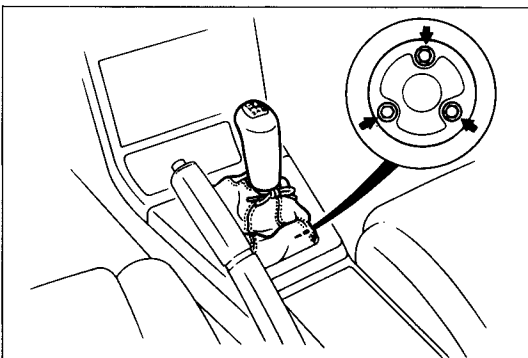

97U0J1-107

16. Install the shift lever.

Tightening torque:

7.8—11 N·m (80—110 cm·kg, 69—95 in·lb)

17. Install the boot panel assembly, boot sheet, and change lever knob.

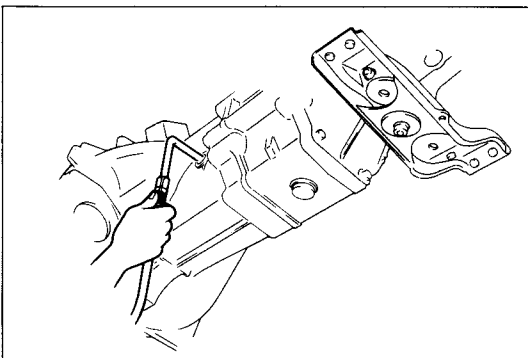

97U0J1-108

18. Add the specified amount of specified transmission oil. (Refer to page J1-7.)

Specified oil

Grade: API service GL-4 or GL-5

All season: SAE 75W-90

Above 10°C (50°F): SAE 80W-90

19. Warm up the engine and transmission oil to normal operating temperature. Check the following:

- 1) Oil leakage
- 2) Transmission operation

97U0J1-109